

Modulation and Transmitters



Al Penney

VO1NO

Modulation

- A pure radio signal (a “**carrier**”) does not convey any information by itself. It **must be changed** in some manner such that a listener can reverse the modification process and recover the information.
- The **process of imparting information** onto the carrier is called **Modulation**.
- Modulation is achieved by **changing the presence, frequency, amplitude or phase** of the carrier wave.
- The process of **recovering that information** is called **Demodulation or Detection**.

Telegraphy

- Simplest method of modulating a signal.
- A **key** is used to **turn the carrier on and off** in accordance with the **Morse Code**.
- **Dits** are one time unit in length, **Dahs** are 3 time units in length.
- Commonly known as **Continuous Wave (CW)**.

Advantages of Continuous Wave

- **Very narrow signal** compared to other modes. Can **squeeze many signals** into a small part of the spectrum.
- **No “accent”** to hinder communications. CW is actually **its own language** with many abbreviations and “Q” signals.
- CW can **“punch through”** under **difficult conditions** where other modes might have difficulty.

How to Send CW

- Old style key (called a “**straight key**”) is still used by many.
- Many use **electronic keyers**, which **automatically** make the Dits and Dahs.
- Some people use **keyboards and computers** to key the transmitter. These methods can also “read” the CW and **display it on the screen**.
- **Mechanical ‘bugs’** can make the Dits, but the Dahs are still made manually.
- Leave between **150 to 500 Hz separation** between **your frequency** and a **contact in progress**.



Straight Key

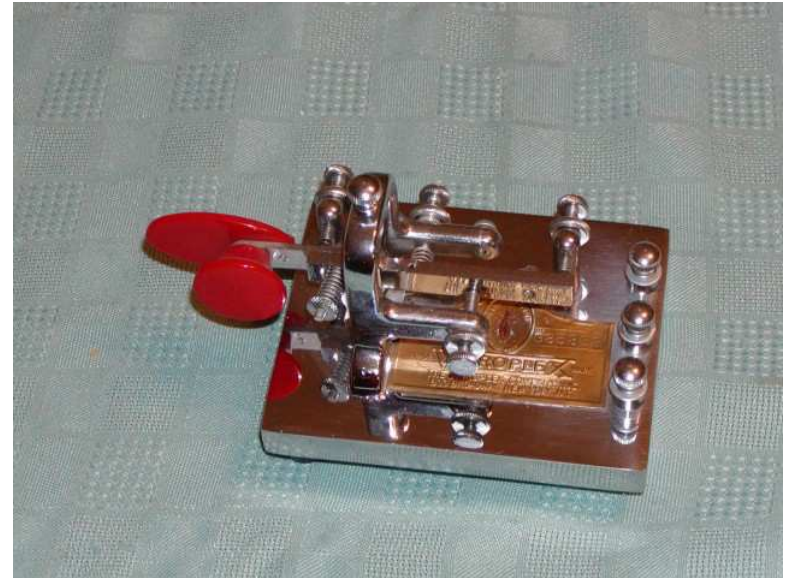

Keyer

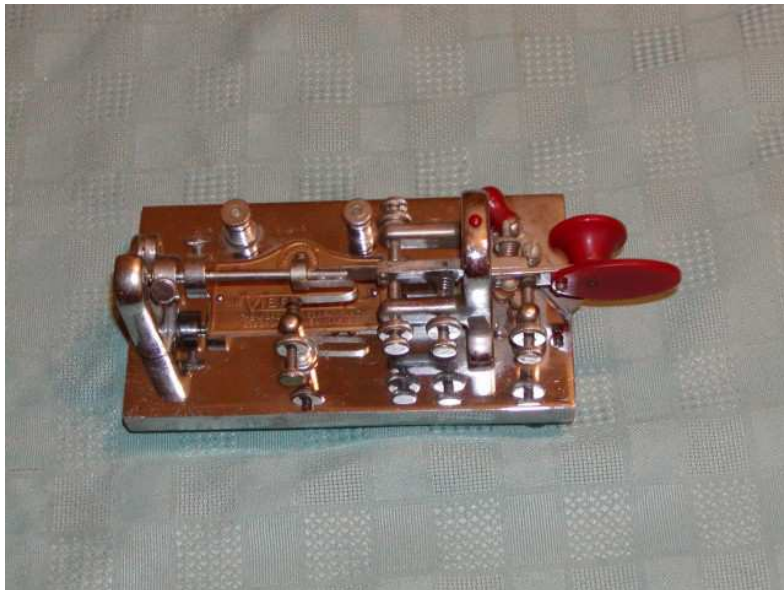

"Bug" Keyer

Amplitude Modulation

- Changes the **instantaneous power** in the radio wave **in time with a modulating signal**.
- The **strength** (amplitude) of the **carrier signal** is made to **vary** in accordance with the **audio signal**.

Amplitude Modulation (AM)

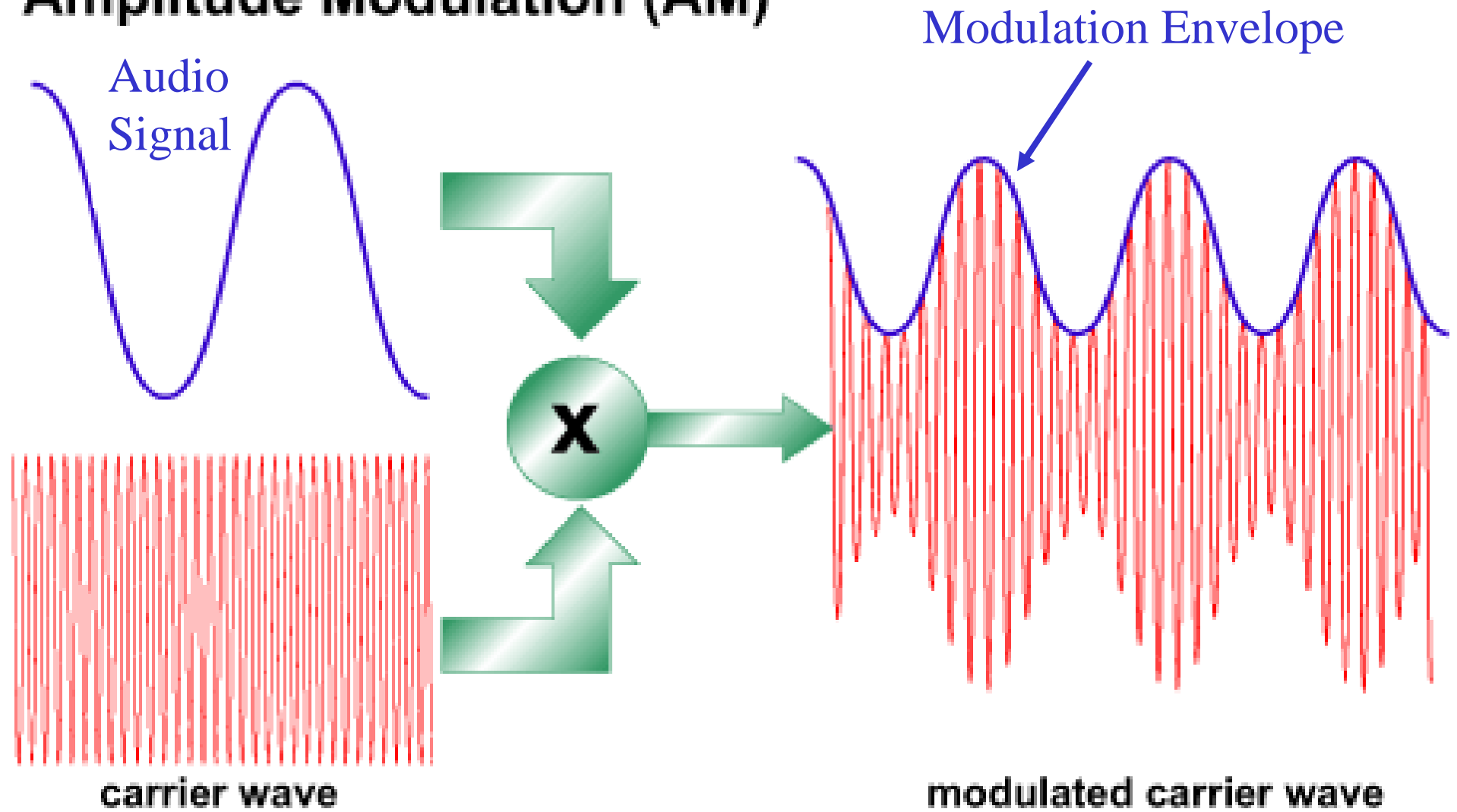

Peak Envelope Power (PEP)

- The **average power** delivered to the antenna transmission line **during one RF cycle**, at the **highest crest of the modulation envelope**.

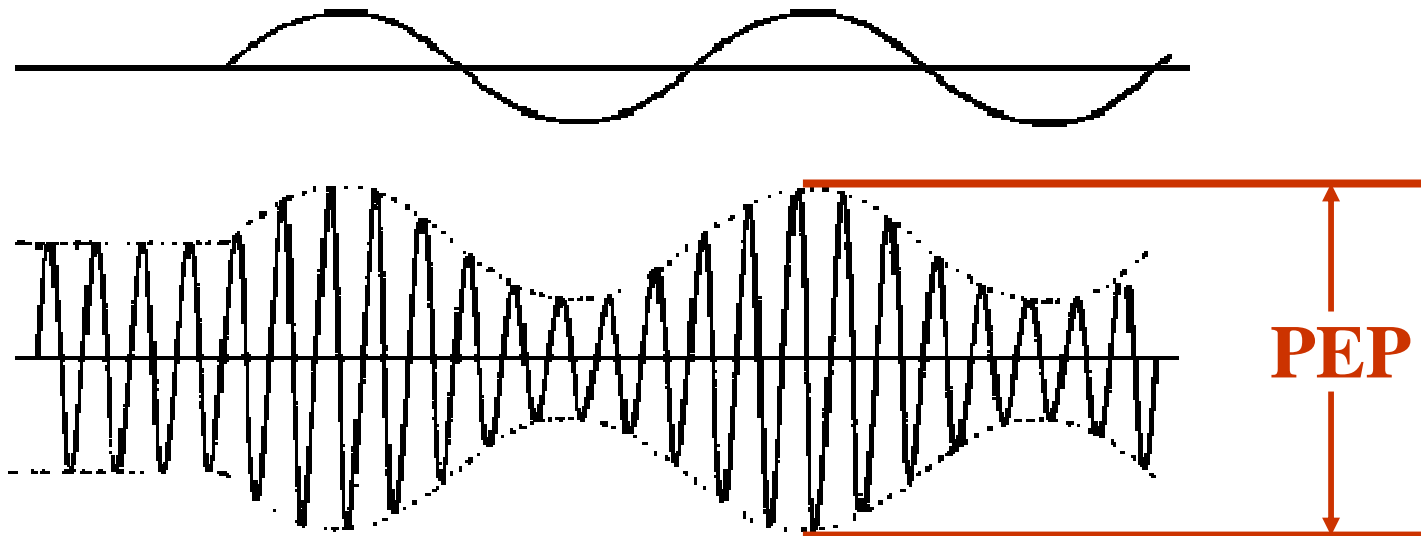

AM Signal Quality

- **Overmodulation** can seriously distort an AM signal.
- If overmodulated, the **negative signal peaks** will **cut off the carrier**, resulting in **serious distortion** and the appearance of **spurious frequencies**.
- Ensure Microphone Gain (**Mic Gain**) and Automatic Level Control (**ALC**) are set as directed by the manufacturer.
- **More is not necessarily better!**

Modulation Percentage

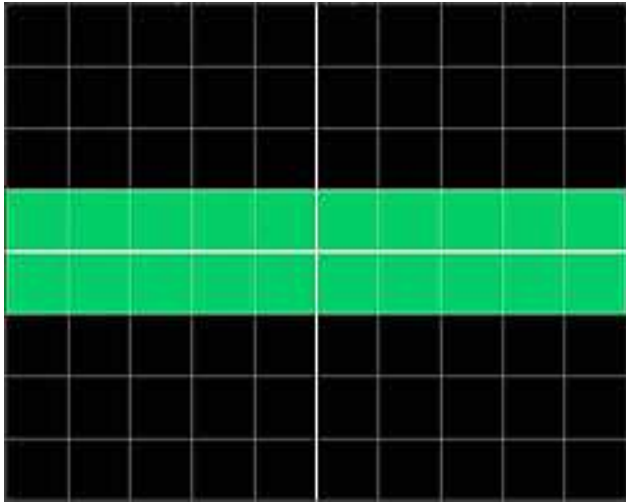

No modulation (straight carrier)

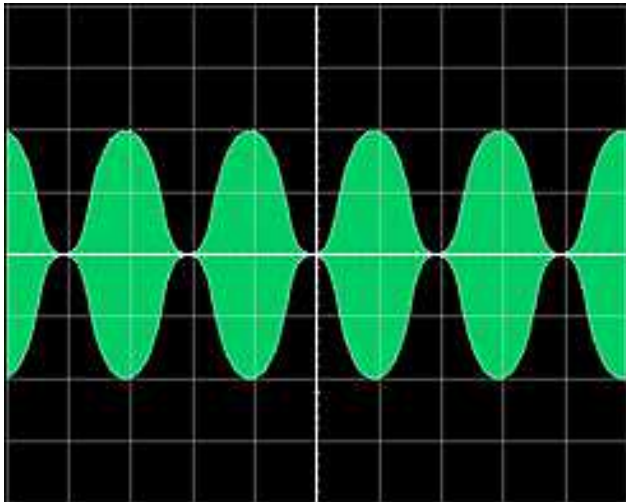

100% modulation

Modulation Percentage

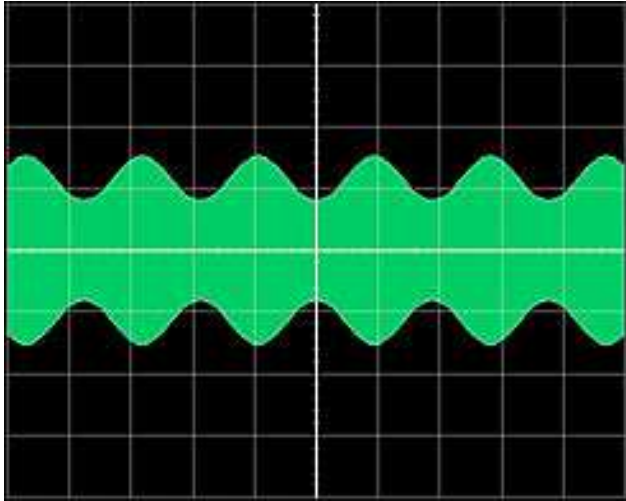

Under Modulated

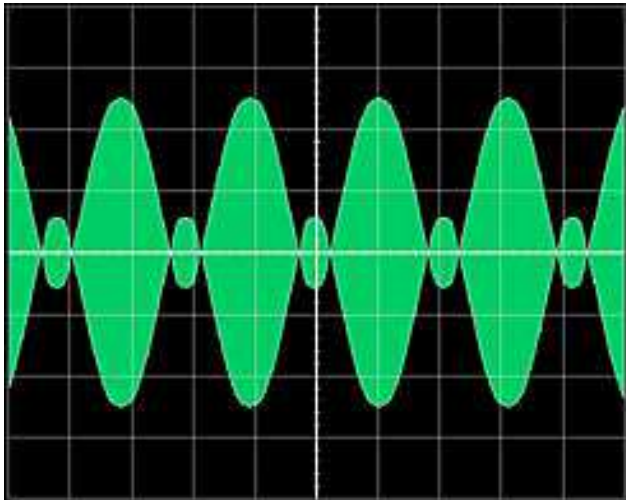

Over Modulated (low level)

Modulation Percentage

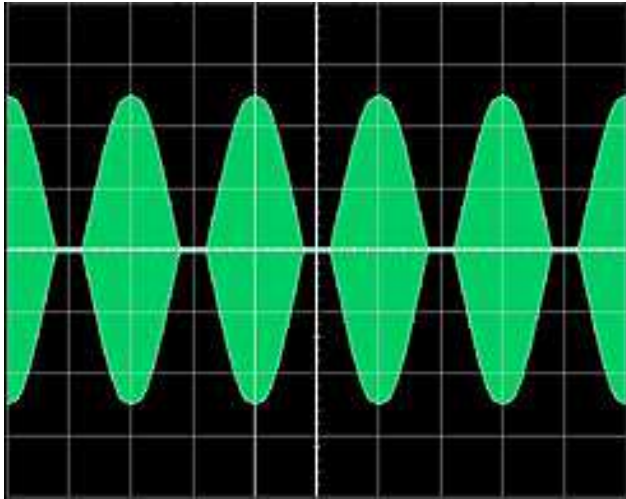

Over modulated (high level)

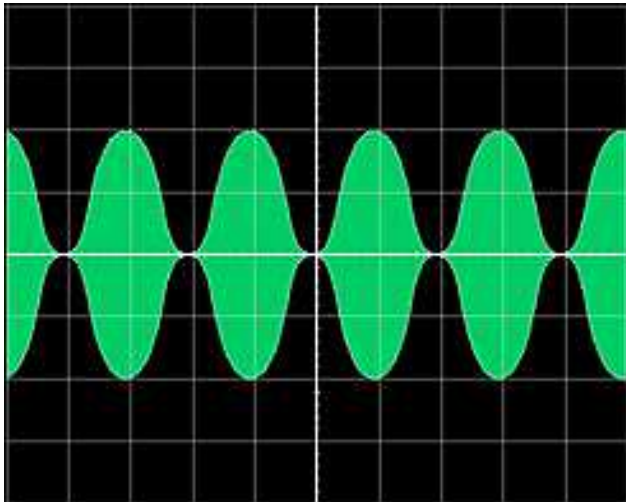

100% modulation

Mixing Signals Together

- When **two signals are mixed together**, the result is **four signals**:
 - The **original two signals**;
 - The **sum of the two original signals**; and
 - The **difference** between the **two original signals**.
- *Example: A carrier signal at 3.8 MHz is modulated by a 1000 Hz tone (0.001 MHz). What are the resulting signals?*

Mixing Signals Together

- *The output is 1000 Hz (not a radio frequency our radio can transmit on so we can ignore it), 3.8 MHz, 3.799 MHz, and 3.801 MHz.*

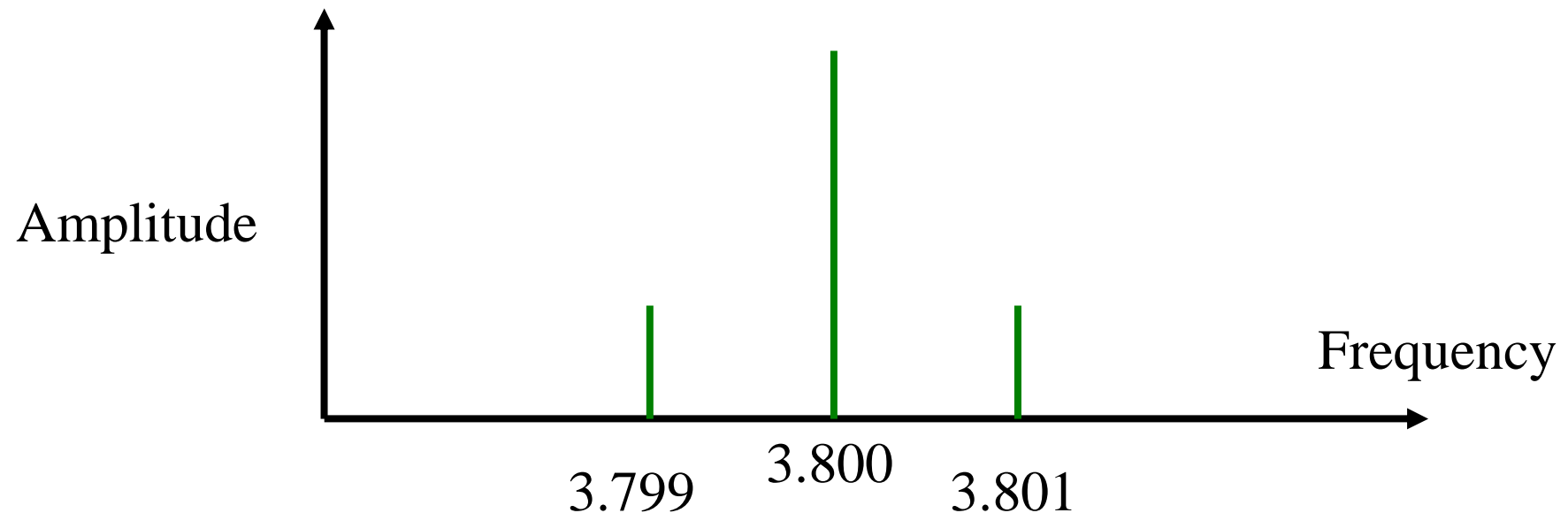

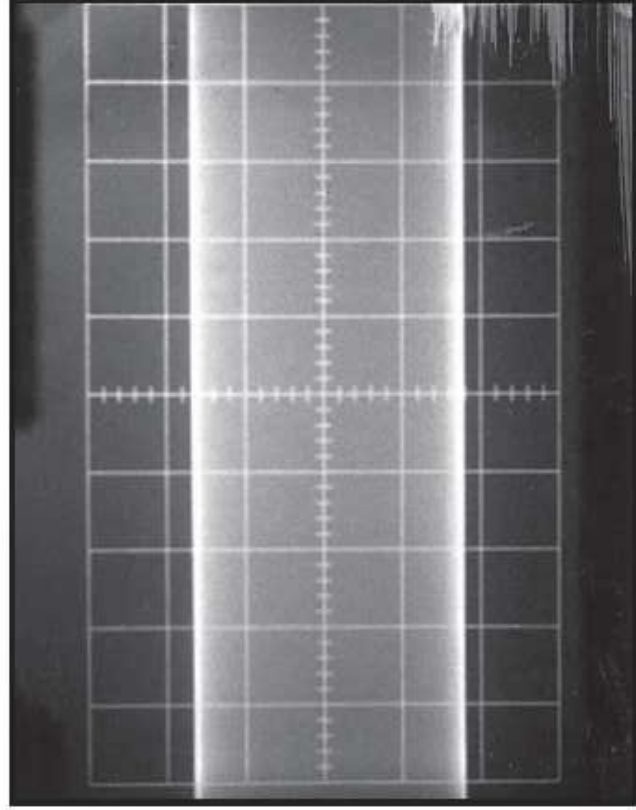
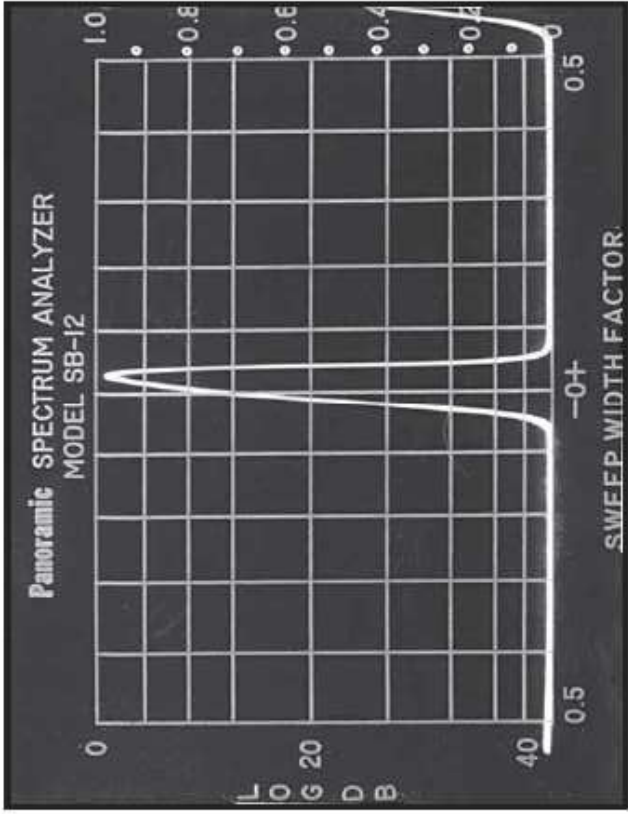

(A)

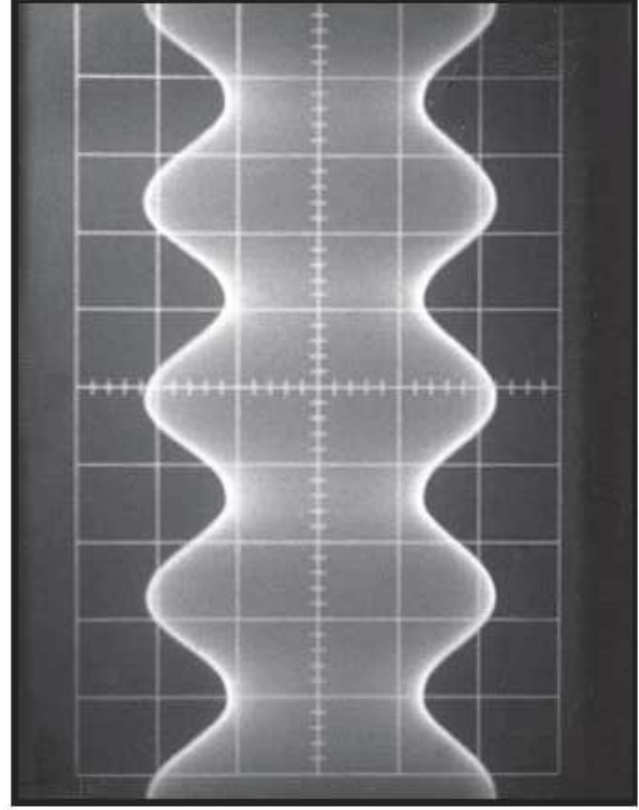
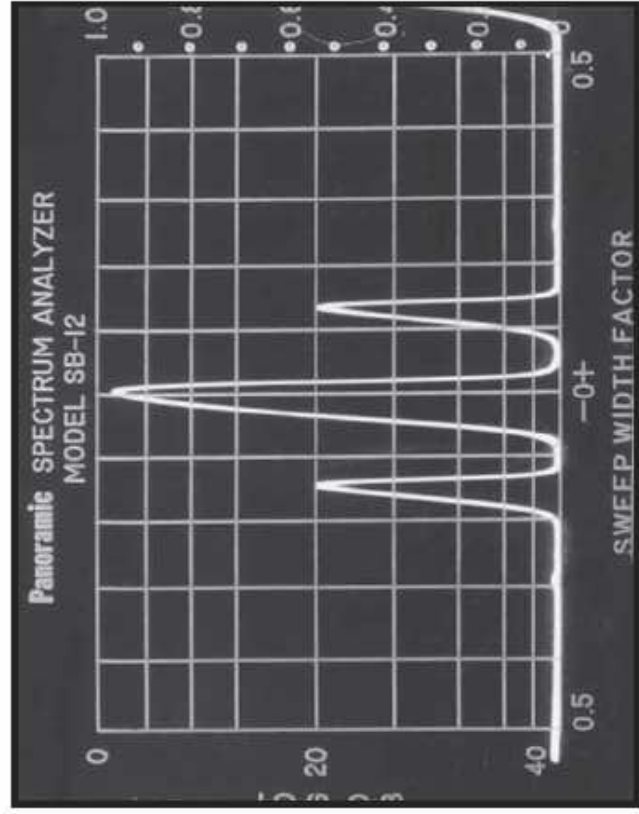

(B)

Sidebands in an AM Signal

- The two new RF frequencies are called **Sidebands**.
- At 100% modulation, the **power** in each sideband is equal to $\frac{1}{4}$ **that of the main carrier**.
- Instead of a single 1000 Hz tone, imagine a range of **Audio Frequencies** from **300 Hz** to **3000 Hz** (0.3 KHz to 3 KHz)...
- Such a range of Audio Frequencies could represent a **human voice**.

Sidebands in an AM Signal

- The **two resulting range of frequencies**, one above and the other below the original carrier frequency, are called the **Upper Sideband (USB)** and the **Lower Sideband (LSB)**.
- These **two sidebands** carry the **same information**.
- Note that **to hear the original audio** on the receiver's speaker, the **two sidebands must mix** with the **original carrier signal**.
- The resulting **sum and difference signals** will be in the **Audio Frequency range**.

Sidebands

Graphical Anatomy of an AM Signal vs. SSB

Copyright 2003 NU9N



The RF bandwidth of a given AM signal is twice that of its audio bandwidth, unlike SSB where RF & AF bandwidths are equal.

Can We Improve AM?

- From the previous diagram, it is evident that each **sideband contains the same information.**
- As well, why transmit the **carrier** if it **contains no information?**
- We are also **occupying twice** as much of the **RF spectrum** as we need by using an AM signal.
- If we could **eliminate one** of the **sidebands** and the **carrier**, might we not also be able to **amplify only what we need** to amplify, thereby putting more power into what is actually required at the other end?

Let's Suppress the Carrier...

- We could **suppress the carrier** and **put the power** into the two sidebands – this is called **Double Sideband Suppressed Carrier**.
- It **still has two sidebands** however, each carrying the **same information**.
- The resulting signal also still takes up **twice the space required**, meaning that **fewer signals** can share the **same amount of spectrum**.

Let's Get Rid of a Sideband Also!

- **One of the sidebands can also be suppressed while still retaining all the information imparted onto the signal.**
- **It doesn't matter which sideband is suppressed.**
- **The result is Single Sideband Suppressed Carrier (SSBSC).**
- **It is more commonly called Single Sideband (SSB).**

Single Sideband

- If the lower sideband is suppressed, the result is **Upper Sideband (USB)**.

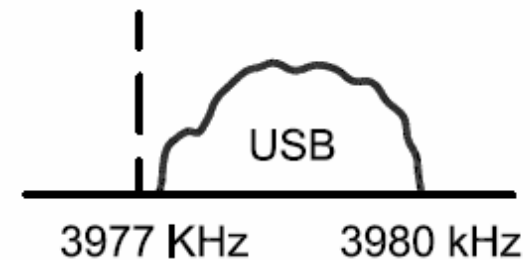

- If the upper sideband is suppressed, the result is **Lower Sideband (LSB)**.

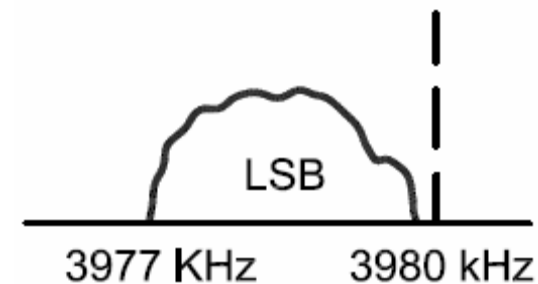

Advantages of Single Sideband

- Available **power is concentrated** into one sideband.
- **Transmitted signal** is much **narrower** than an AM signal.
- Overall, SSB is up to **8 times more efficient** than an AM signal.
- The price to pay is that SSB **circuitry is more complex** than AM, both in the transmitter and in the receiver.

Notes on SSB

- **LSB** is used on **160, 80 and 40** Meter bands.
- **USB** is used on **all other bands**.
- Amateurs specify the **carrier frequency** when describing their operating frequency, even though no signal is actually transmitted there!
- Although SSB dates to the 1930s, Amateur interest didn't start until the 1950s.
- It gained popularity steadily, and by the 1970s was the **standard voice mode** on the **HF bands**.

Frequency Modulation (FM)

- In **Frequency Modulation**, the **frequency** of the **carrier** is varied in accordance with the **variations in the modulating signal**.
- The **amount** by which the **carrier frequency** is **raised or lowered** from its normal value is called the **Deviation**.

Frequency Modulation (FM)

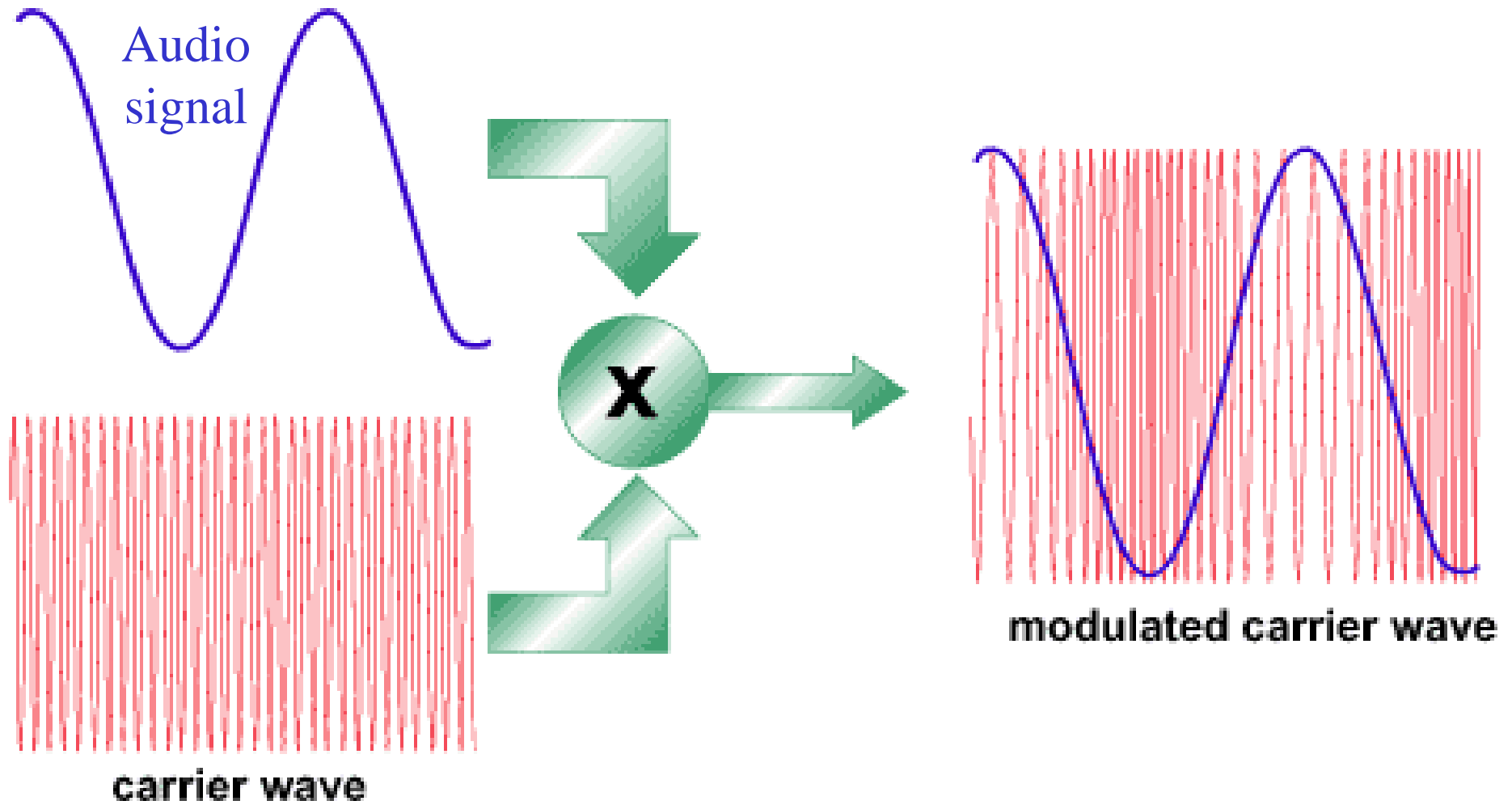

Notes on Frequency Modulation

- The **maximum deviation** of an FM communications system must be **defined in advance** – this is the **100% modulation** point.
- **Under-deviation** results in weak, “**thin**” audio.
- **Over-deviation** will cause the audio to be **distorted**, and will **splatter** onto adjacent frequencies. It may also break up. To correct this, hold the microphone further away.
- FM is known for **clear, high fidelity audio** and **immunity to static**, as well as **Capture Effect**.

Capture Effect

- **Capture Effect** is a phenomenon associated with **FM reception** in which **only the stronger of two signals** at, or near, the same frequency **will be demodulated**.
- The capture effect is defined as the **complete suppression of the weaker signal** at the receiver limiter (if it has one) where the weaker signal is not amplified, but attenuated. When both signals are nearly equal in strength, or are fading independently, the receiver may **switch from one to the other** and **exhibit picket fencing**.

Amateur Radio FM

- Hams use **Narrow Band FM (NBFM)**, which has a **maximum deviation of 5 KHz**. The **maximum modulating frequency** should be **3 KHz**. Commercial stations use 75 KHz.
- **Total bandwidth** required is **16 KHz**, so **FM is not allowed on HF bands EXCEPT 10M**.
- **Most FM** is found on the **2M** and **70cm** bands.

Phase Modulation

- **Phase Modulation** is similar to FM, but instead of changing the frequency of the carrier, the **phase is changed** instead.
- **Phase Modulation is generated by a reactance modulator connected to an RF power amplifier!**
- This is the only question I can find about Phase Modulation on the question bank!

Digital Modes

- **Digital** refers to a set of points that have **only 2 values** – on/off, 1 and 0, up or down etc.
- In Amateur Radio, this generally refers to **computer to computer**, or at least **terminal to terminal** systems.
- **Characters** are coded with a **series of 1's and 0's** called **bits**.
- A series of **8 related bits** is called a **byte**.

Digital Coding

- A **byte** could have up to **256 different values** ($2^8 = 2 \times 2 \times 2 \times 2 \times 2 \times 2 \times 2 \times 2$).
- The rate of signalling is called the **baud**, which indicates the **number of signal changes per second**.
- **One signal change** could carry **more than one bit of information**, so a signal at 2400 baud could reflect a data transmission rate of 9600 bits per second for example.

Digital versus Analog

- **Noise** (static) is **less of a problem** because information has **only 2 levels**.
- **Characters** can be **coded** with additional information called **parity bits** – the number of “1” bits in a character is always odd or even as specified by the coding system.
- Receive system **confirms the parity** of the byte, and will know if there is a discrepancy.
- Sometimes the byte can be **corrected**, or a **re-transmission** can be requested.

Radio Teletype

- The **first digital mode** used by **Amateurs**.
- Bits known as **mark** and **space**, mapped to two different frequencies, usually **170 Hz apart**.
- This **frequency difference** is called the **shift**.
- Transmitted at **60 words per minute**.

Baudot Code

- Uses **5 bit groups**, so only **32 unique characters** are possible (2^5).
- In order to include the alphabet, numbers and special characters, the **code set is used twice**, with an “**upper**” and “**lower**” character used to switch between the two sets.
- Baud rate is 45.5

Model 19 Teletype Set



RTTY Transmission

- Transmission is a **shifted carrier**, where the **carrier rests on the mark frequency**, and is **shifted 170 Hz** to the **space frequency**.
- To **minimize interference** with adjacent stations, try to stay **250 to 500 Hz away**.
- Use **LSB for RTTY**, regardless of the band.

RTTY Transmission

- **Mark frequency is 2125 Hz, Space is 2295 Hz** (away from the frequency displayed by the radio's readout).
- **Some systems will key the transmitter directly**, alternating directly between the mark and space. This is called **FSK (Frequency Shift Keying)**.
- Most Hams use a **computer soundcard** connected to the **microphone input** of the radio.
- **Two tones**, corresponding to mark and space, are **sent to the mic input** when the radio is keyed. This is called **Audio Frequency Shift Keying (AFSK)**, but is indistinguishable from FSK.

RTTY Tuning Aid

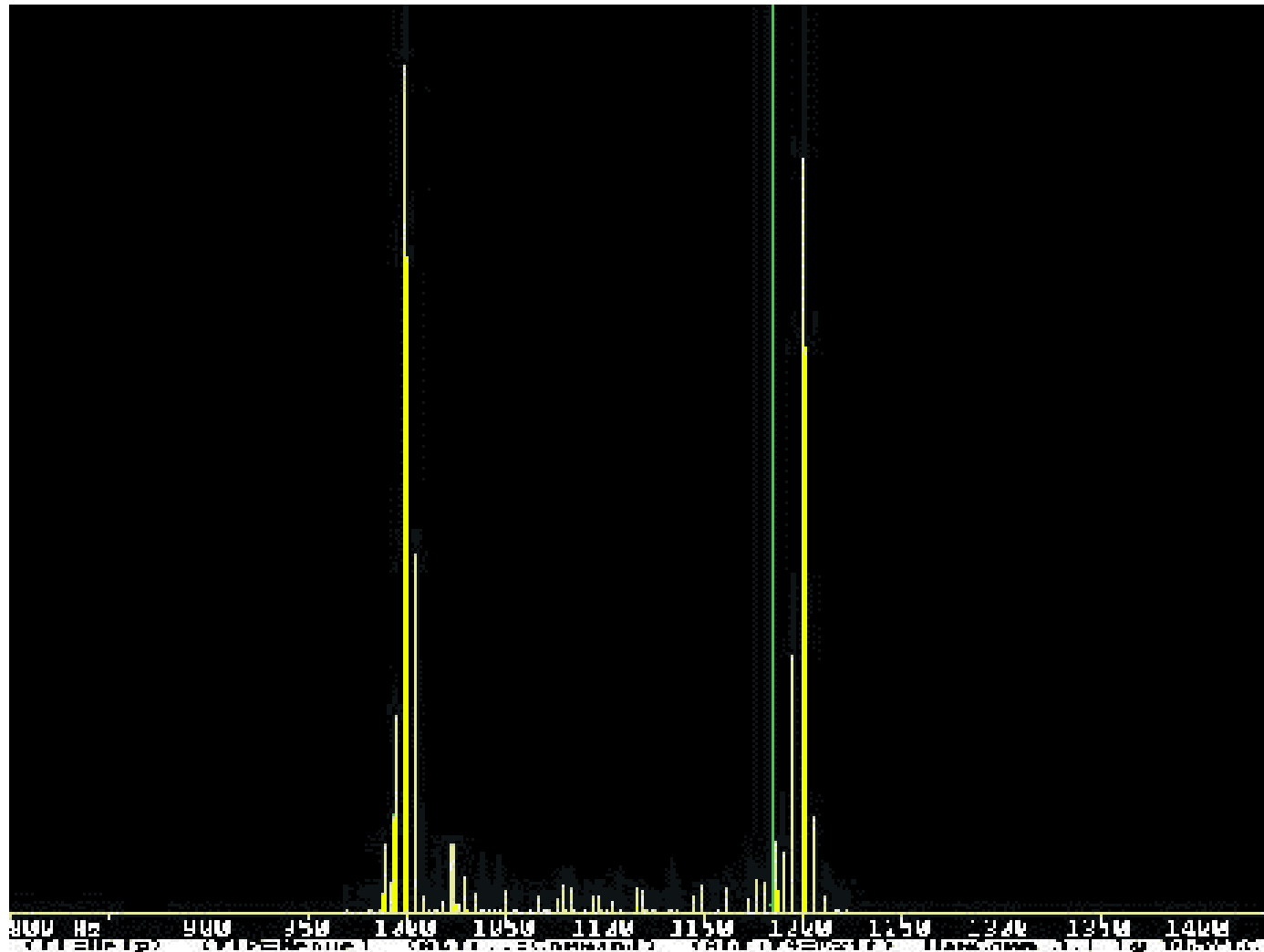

Packet Radio

- **Computer to computer mode** that once was the most popular digital mode, particularly on 2M.
- **Data** is bundled into **packets** of information.
- A **Terminal Node Controller (TNC)** is used to connect the radio with the computer.
- **VHF Packet** is sent at **1200 baud**.
- **HF Packet** is sent at **300 baud**.
- Uses **8-bit ASCII** code (American Standard Code for Information Interchange).

Figure 1 - Packet Radio Station

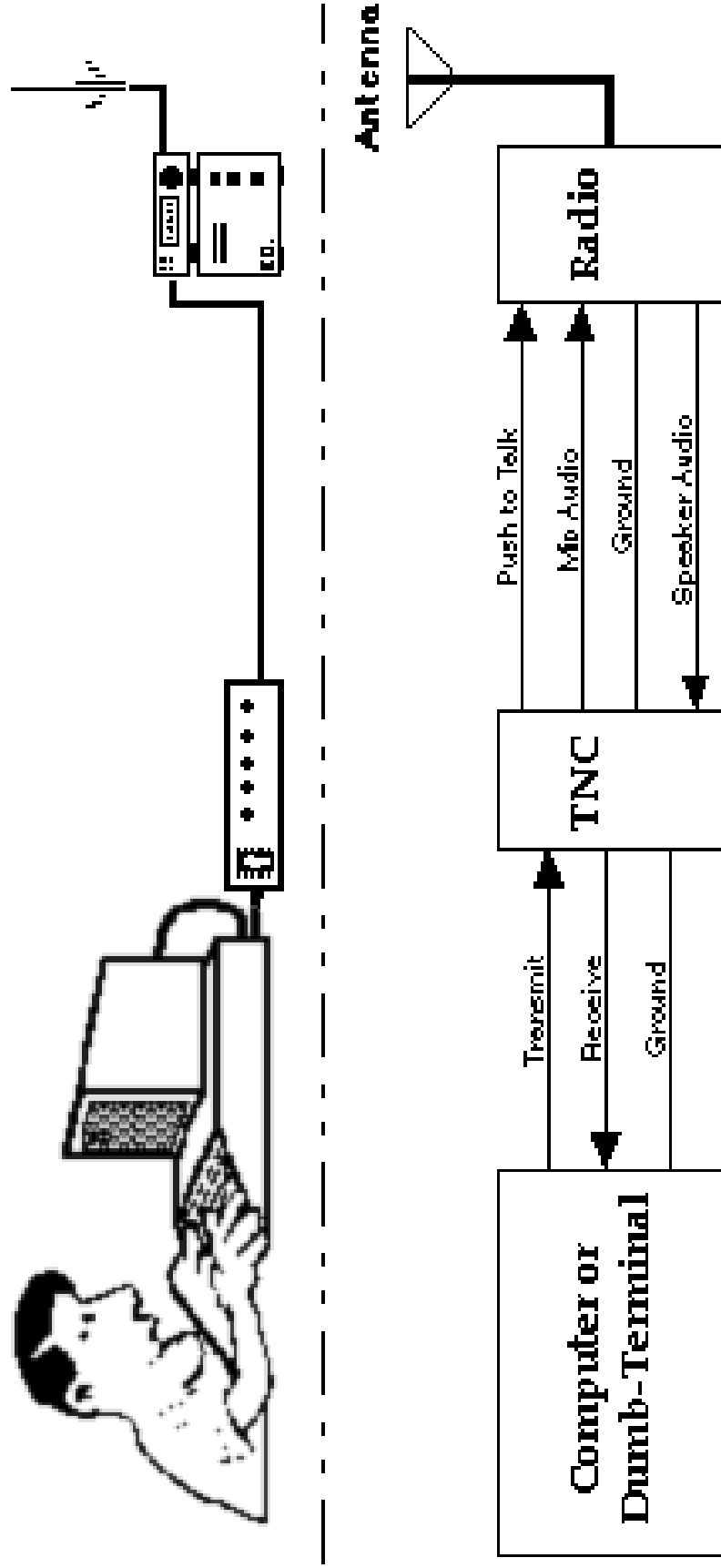

Packet Radio

- Stations are linked by the **Connected** mode, ensuring that packets are re-transmitted if not received properly.
- **Each packet** requires an “**Acknowledgement**”.
- You can see **what traffic is being sent** without being connected by using the “**Monitor**” mode.
- Repeaters called **Digipeaters** are used to **receive, store and re-transmit packets** in order to extend the range, sometimes into a **network of digipeaters**.
- The **protocol** used to transmit **Packet data** is called **AX.25**.

Automatic Packet Reporting System

- An Amateur Radio-based system for **real time tactical digital communications** of information of immediate value in the local area.
- Now the **primary use of Packet Radio**.
- Displays **position, weather info, announcements etc.** in an unconnected broadcast manner.
- Retransmitted using **digipeaters** and the **Internet**.
- **Maps** are an **integral part** of the system.

Laptop running Urvview with
Precision Maps V5

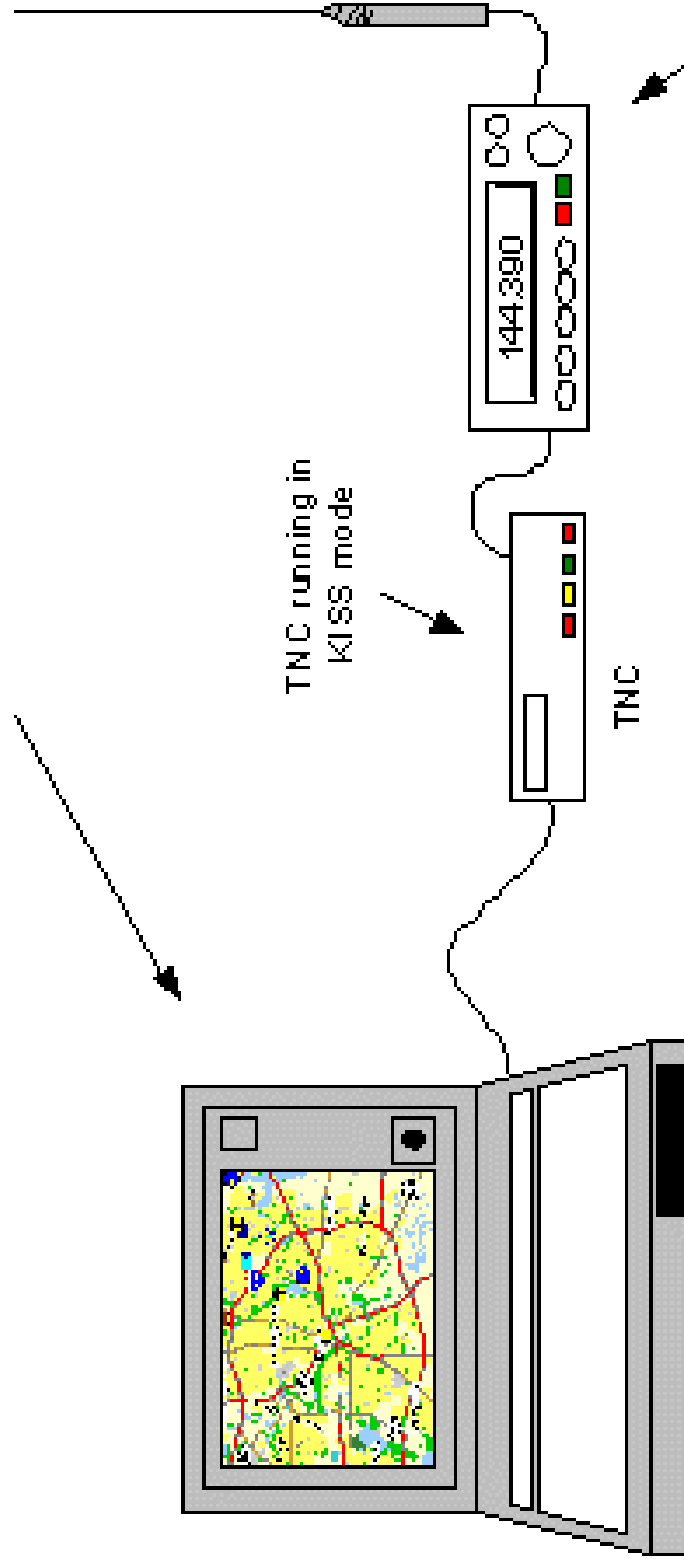

Laptop computer

Portable APRS Station Set-up

* Transceiver and TNC need +12 VDC power.

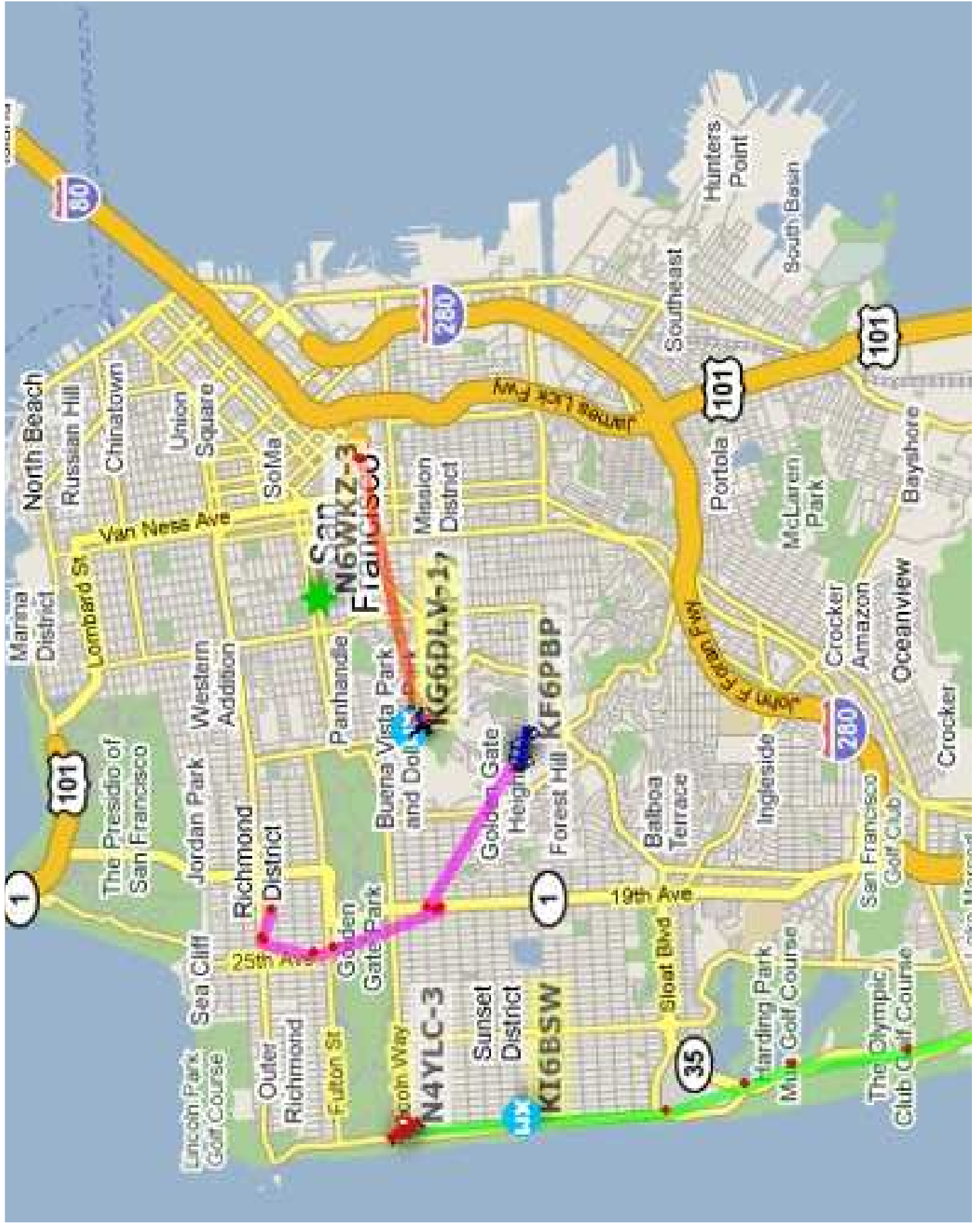

AMTOR

- Amateur Teleprinting Over Radio.
- **Rarely** used today.
- For the test: **Mode A uses Automatic Repeat Request (ARQ) protocol and is normally used for one-on-one communications after contact has been established.**

Phase Shift Keying 31 (PSK 31)

- **The most popular HF digital mode at present.**
- It combines the advantages of a simple **variable length text code** with a narrow bandwidth **phase-shift keying (PSK)** signal using DSP techniques.
- Uses a **simple interface** between the **radio and computer sound card.**
- **Excellent low power capabilities.**

UA1ACO - DigiPan

File Edit Mode Set View Configure Help

Call 1 CQ Call 3 Call BTU Signoff Send Clear TX RX Save Search QSO

Call: Name: QTH:

**ni tnen for sour nice rig s
description there in Siracusa.....
This is DJ3TPræs PSK t31 station setup:
Transceiver: Kenwood TS-950SD
Antenna: Fritzell FB-33 3-el Triband Yngi
PSK-31 terminal: SCS PTC-2 DSP Multimode terminal
Computer: PC Pentium 233 MMX
Software: RC fRTTY V. 1.32
Fine on your LOGGER program . |**

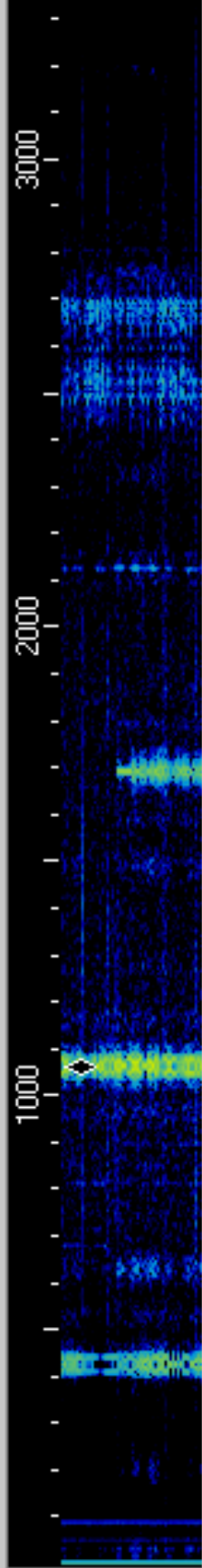

For help, press Alt-H. RX AFC Snap 1063,0 Hz IMD: BPSK 06.01.00 10:49:08

Sound Card Modes

- The introduction of **simple interfaces** between computers and radios has **revolutionized** Amateur Radio digital modes.
- As **new modes** are developed, they can be **downloaded free** of charge.

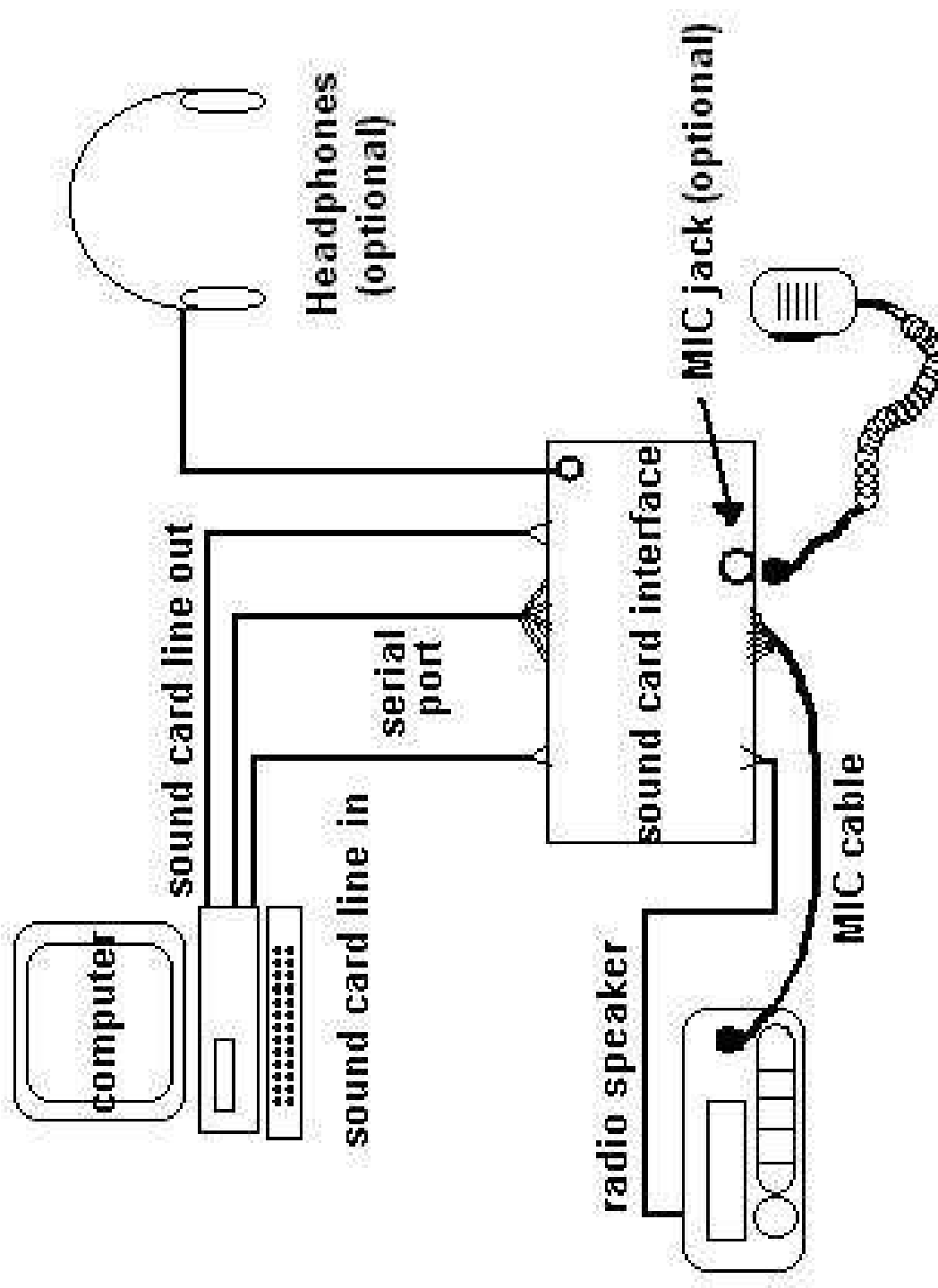

Basic station hookup diagram.

Note: This diagram is a basic sound card station hookup and does not show a keying connection for CW and/or FSK. That connection is user supplied and requires an 1/8" mini jack to connect the key out of the RIGblaster to the radio's straight key input and/or FSK keying terminals.

TRANSMIT AUDIO: Supplied 3.5 mm, 1/8" stereo phone plug patch cord from computer's line* output to RIGblaster's audio in.

PTT, KEYING & SWITCHING: Supplied DB9M to DB9F serial cable connected between the RIGblaster's serial jack and computer's com port. (not needed for VOX)

RECEIVE AUDIO: Supplied 3.5mm, 1/8" stereo phone plug patch cord from radio's speaker or line out to computer's line* input.

COMPUTER SPEAKER RE-CONNECT: Cable from computer speaker re-connects to RIGblaster's audio output

MICROPHONE: Mic. cable supplied with RIGblaster. Connection goes to front of RIGblaster for RJ45 modular radios.

* For laptop computers use the computer's mic. input in place of the line input and use the headphone output in place of the line output.

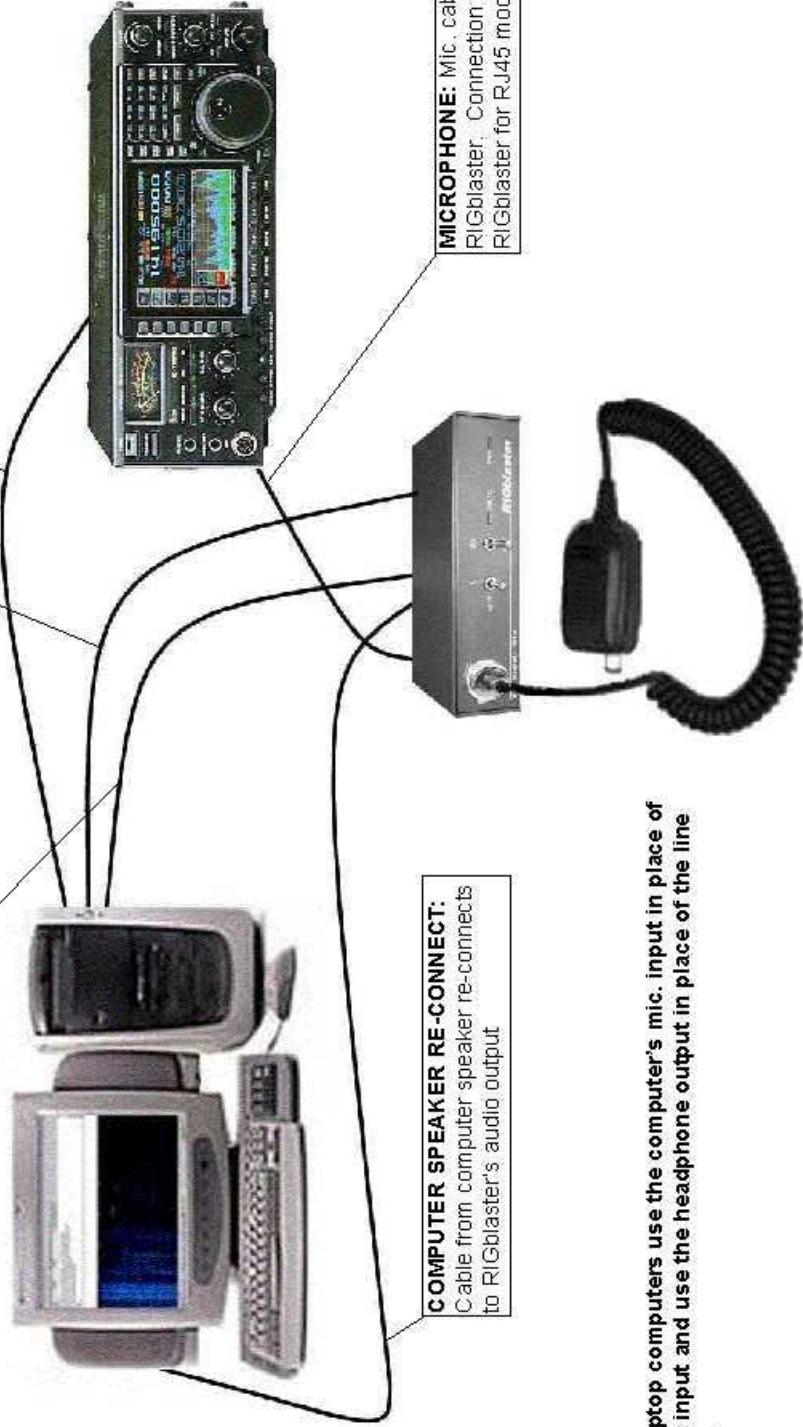

Sound Card Modes

- PSK31
- WSJT
- RTTY
- Hellschreiber
- MT63
- Throb
- MFSK16
- Etc. Etc. Etc.

Slow Scan TV (SSTV)

- Unlike commercial TV which requires up to 6 MHz of bandwidth, **SSTV** transmits pictures using the **same bandwidth as an SSB voice signal** (2.7 KHz).
- The **cost** is the **rate** at which pictures are transmitted – it takes **8 seconds/frame** for the fastest mode, and up to **72 seconds/frame** for more detailed, colour pictures.

Fast Scan TV

- More frequently called **ATV (Amateur TV)**.
- Uses the same **NTSC format** that regular (non-HD) TV uses.
- Because of the **bandwidth requirements**, it is **limited to the 70cm band and higher**.
- ATV Repeaters can be found in the 903 MHz and 1.2 GHz bands.
- Video signal is AM, while audio is FM.

VAG6DX Amateur Television

Miquelon Lake
Alberta



Questions?



Transmitters

Transmitters

- A **transmitter** must accomplish the following:
 - **Generate RF energy** at the desired frequency;
 - **Superimpose information** on the radio waves (ie: modulate the signal).
 - **Increase the strength** of the signal as required (amplify the signal).
 - **Radiate** the RF energy via an antenna.

CW Transmitter

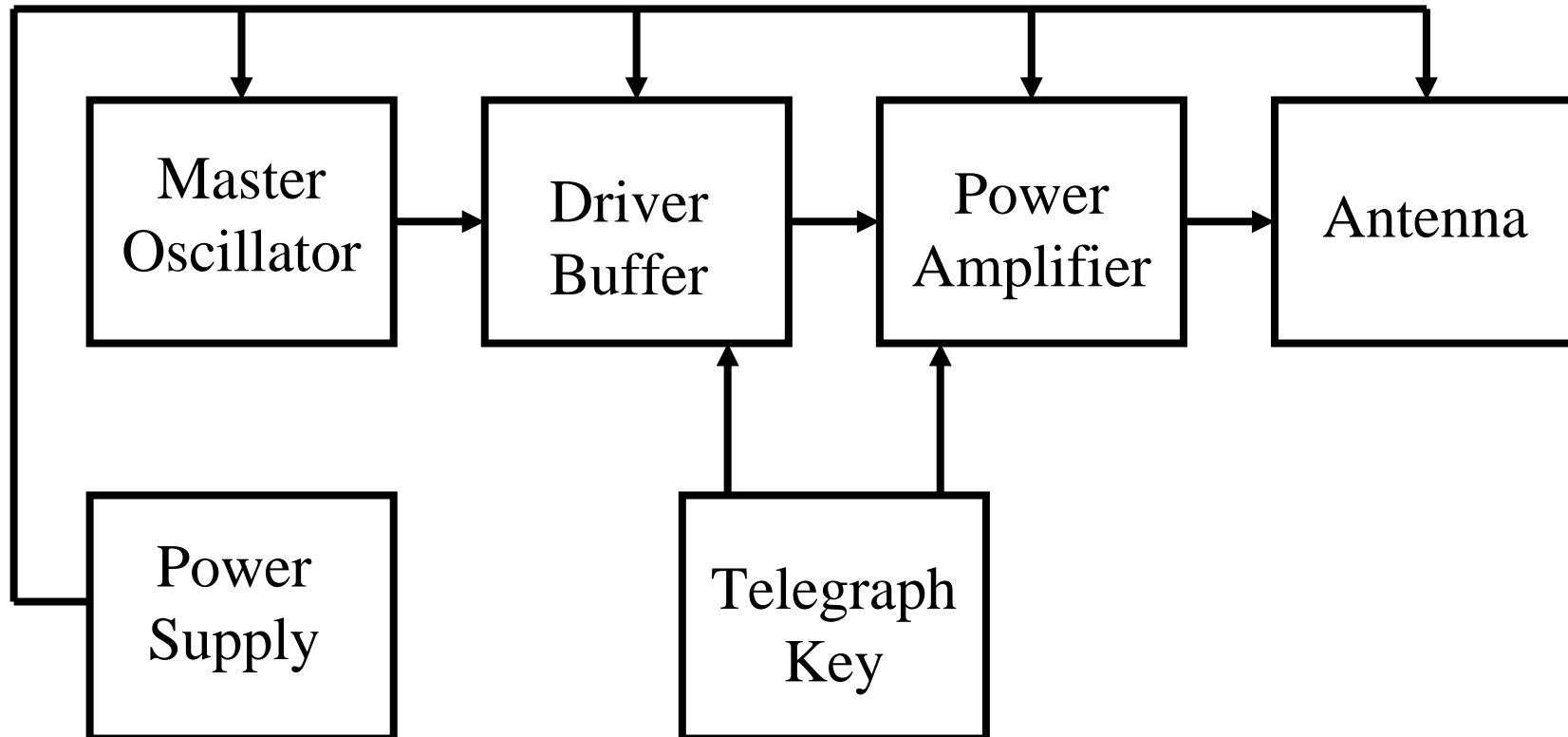

CW Transmitter

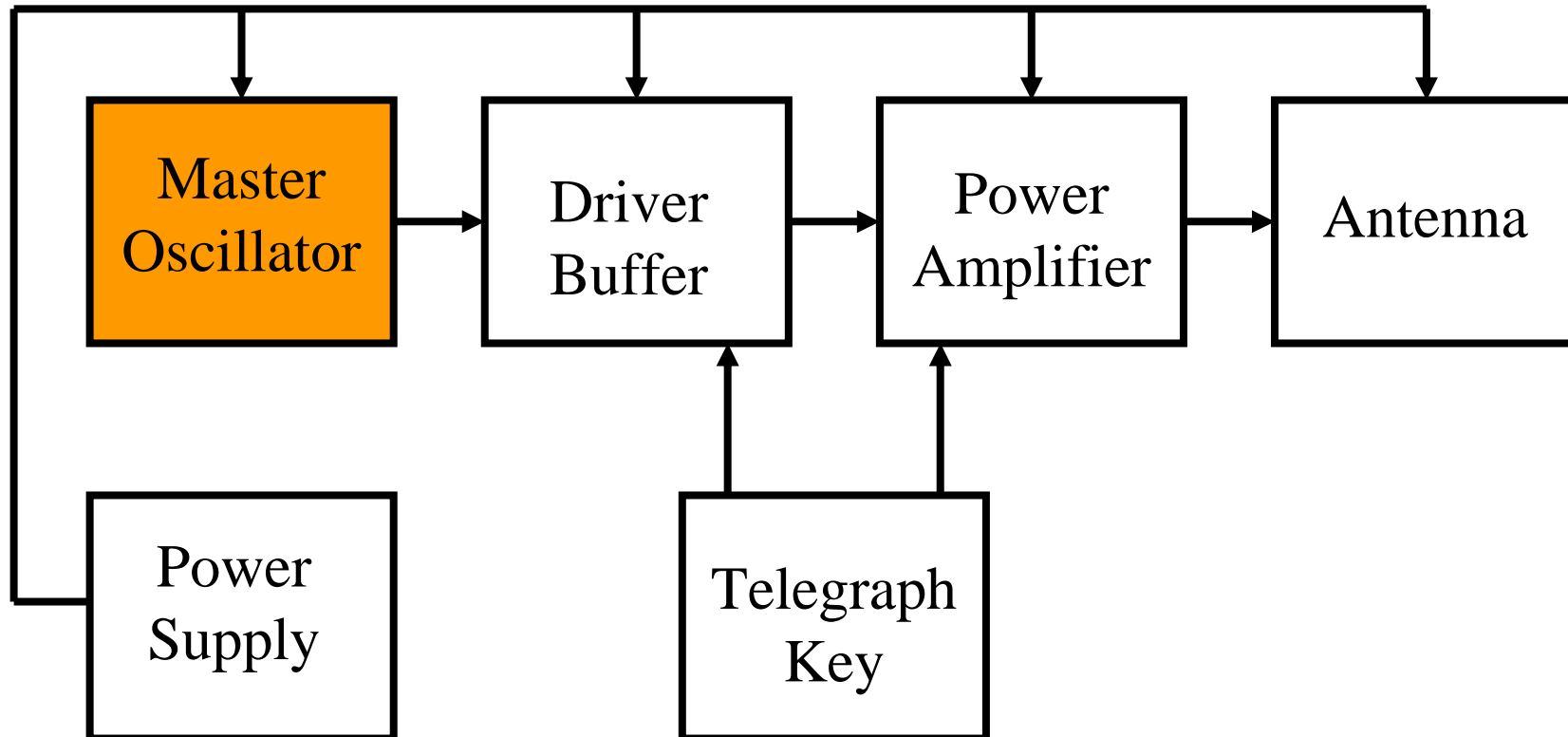

Master Oscillator

- Produces **Radio Frequency (RF) energy**.
- Highly **stable oscillator** that produces RF at a low level.
- Built to resist **drift – unintended frequency variations** – and so is electrically and mechanically stable.
- **Drift** can be caused by **heat, vibration, power fluctuations** etc.
- Oscillator is often a **sub-harmonic** of the desired transmit frequency.

CW Transmitter

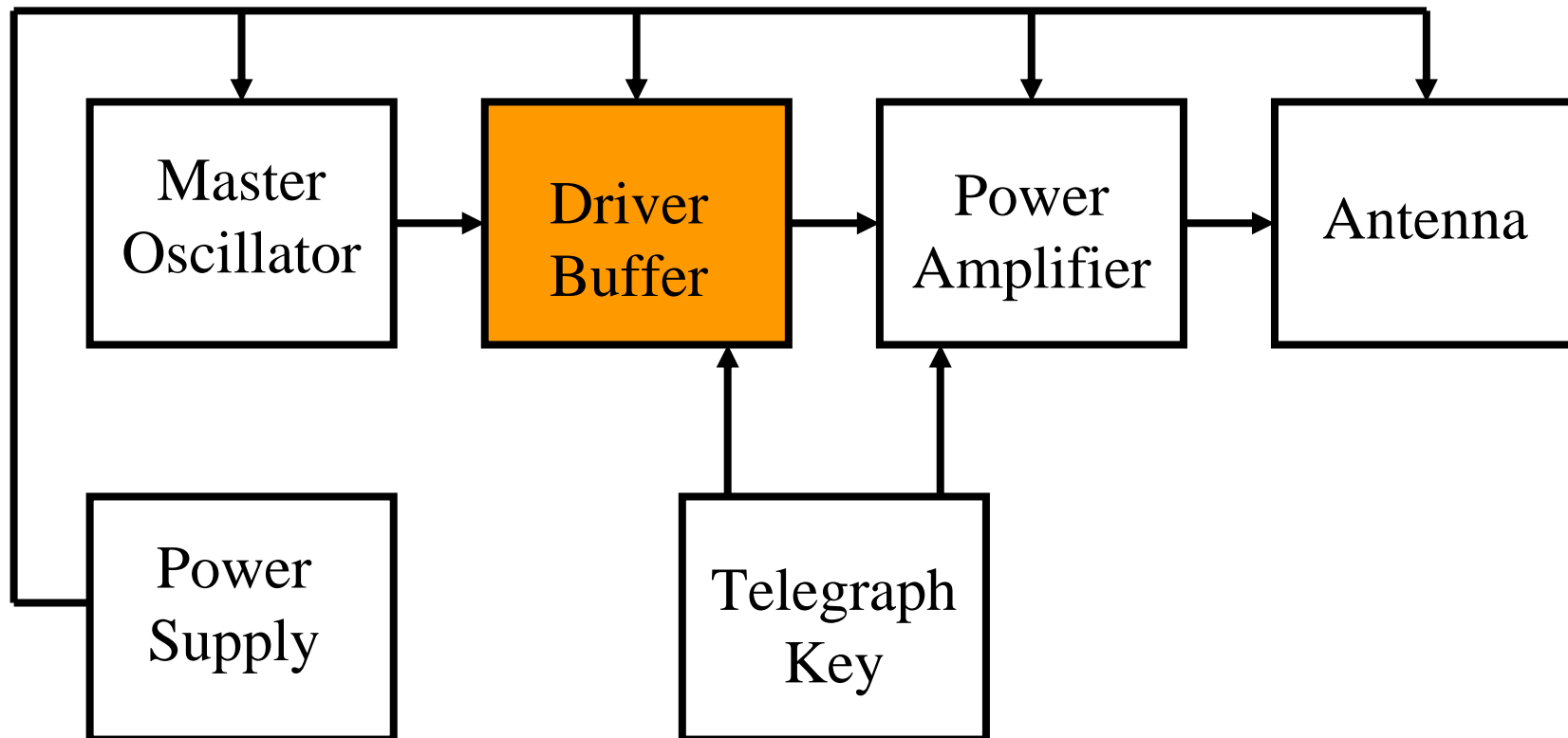

Driver Buffer

- **Isolates the Master Oscillator from the Power Amplifier (PA).**
- Necessary to **prevent variations** in the output load of the PA from affecting the **stability of the Master Oscillator.**

CW Transmitter

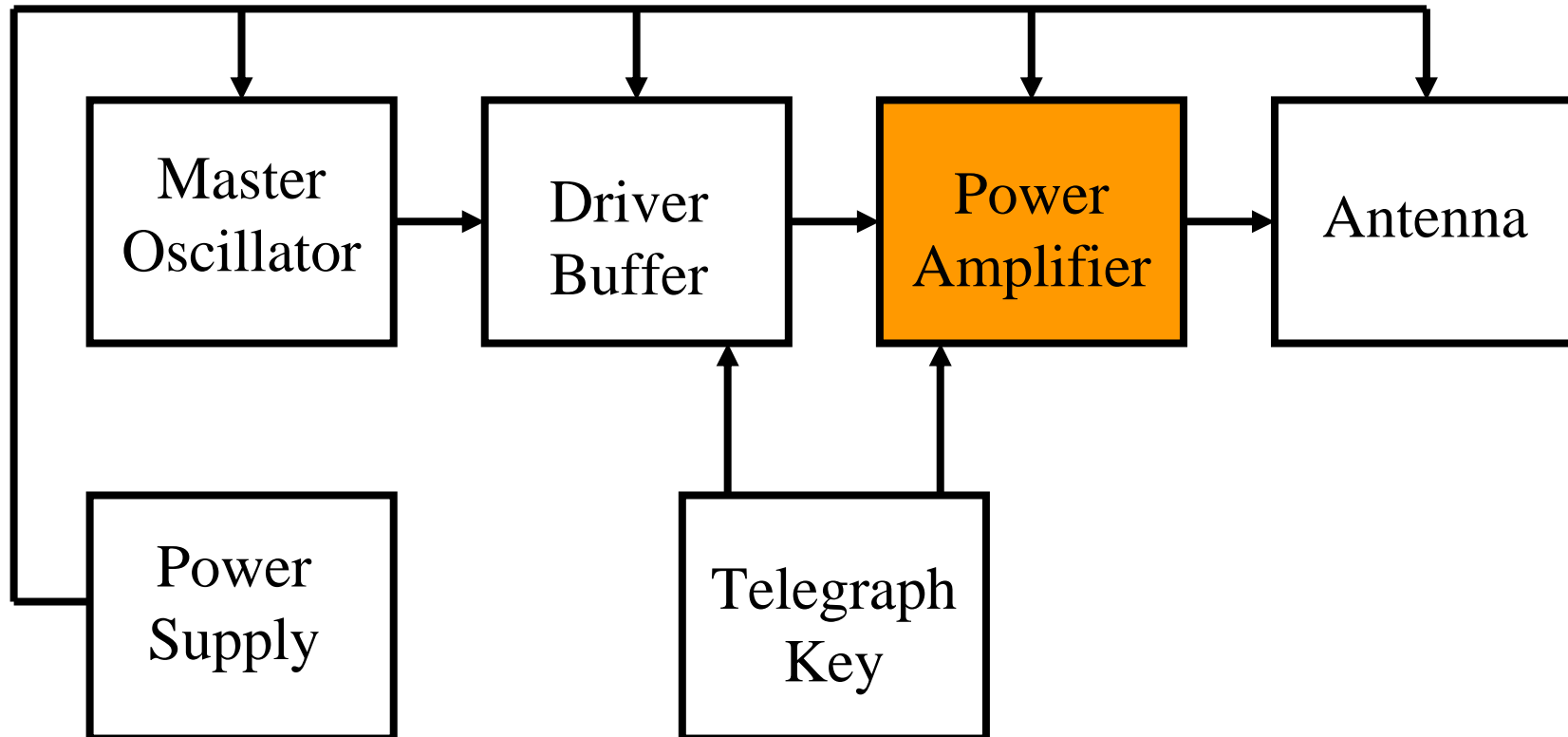

Power Amplifier

- **Takes low level RF signal** from the Buffer stage and **amplifies it** to 100 watts or more to feed the antenna.
- It is **possible to key the Master Oscillator** to key the transmitter, **but that can cause key clicks, chirp etc.**
- A **simpler option** is to key the Driver Buffer and/or buffer stage.

CW Transmitter

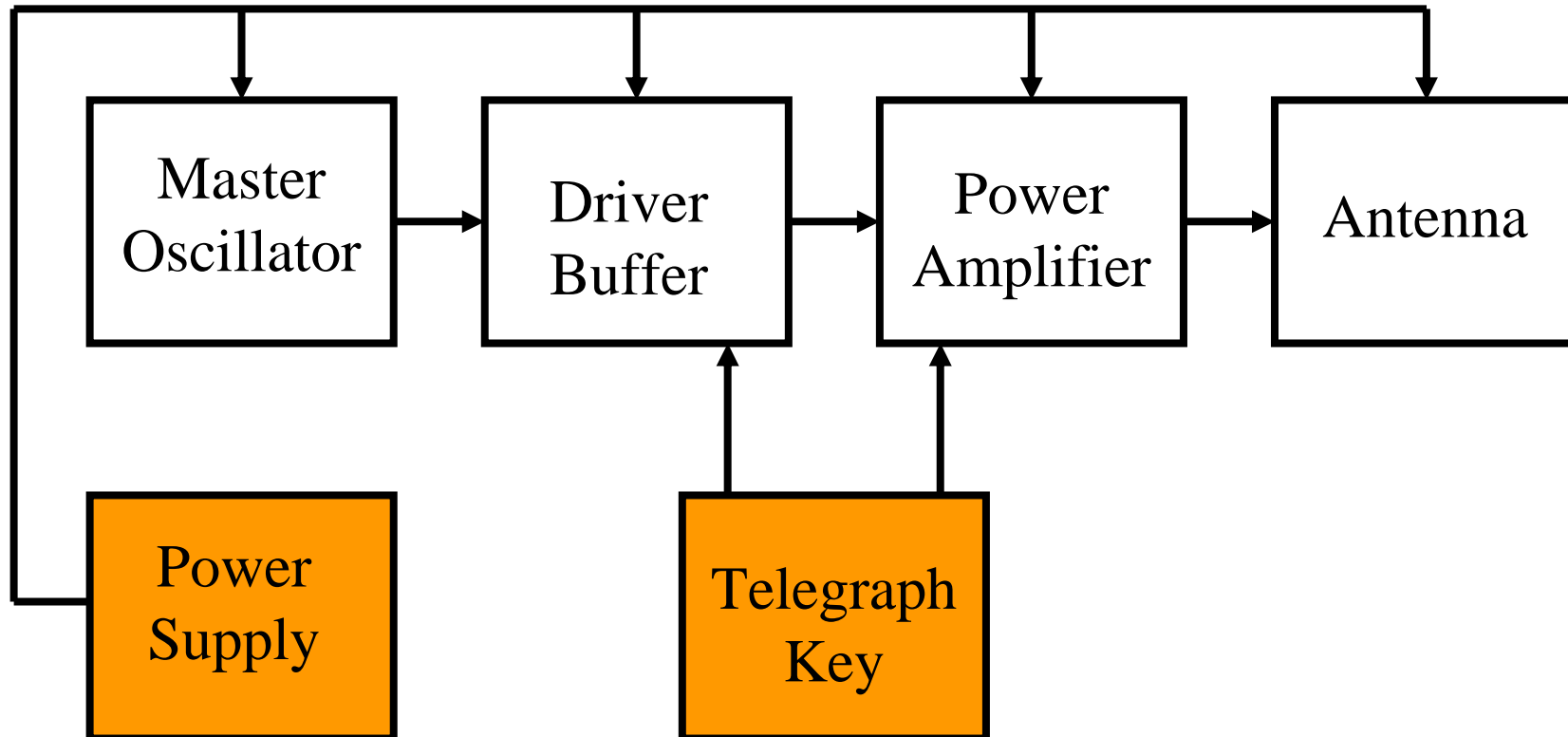

Key and Power Supply

- The **Key** is essentially an **on/off switch** that controls when the **RF energy** is applied to the antenna.
- The **Power Supply** provides the **voltages required** by the transmitter. For solid state equipment this is usually **13.8 VDC**, though some radios need 24 VDC for the Power FETs that make up the PA. Tube gear needs **6.3 VAC** for the **filaments** and various **high DC voltages** for the **plates** and **screens**.

AM Transmitter

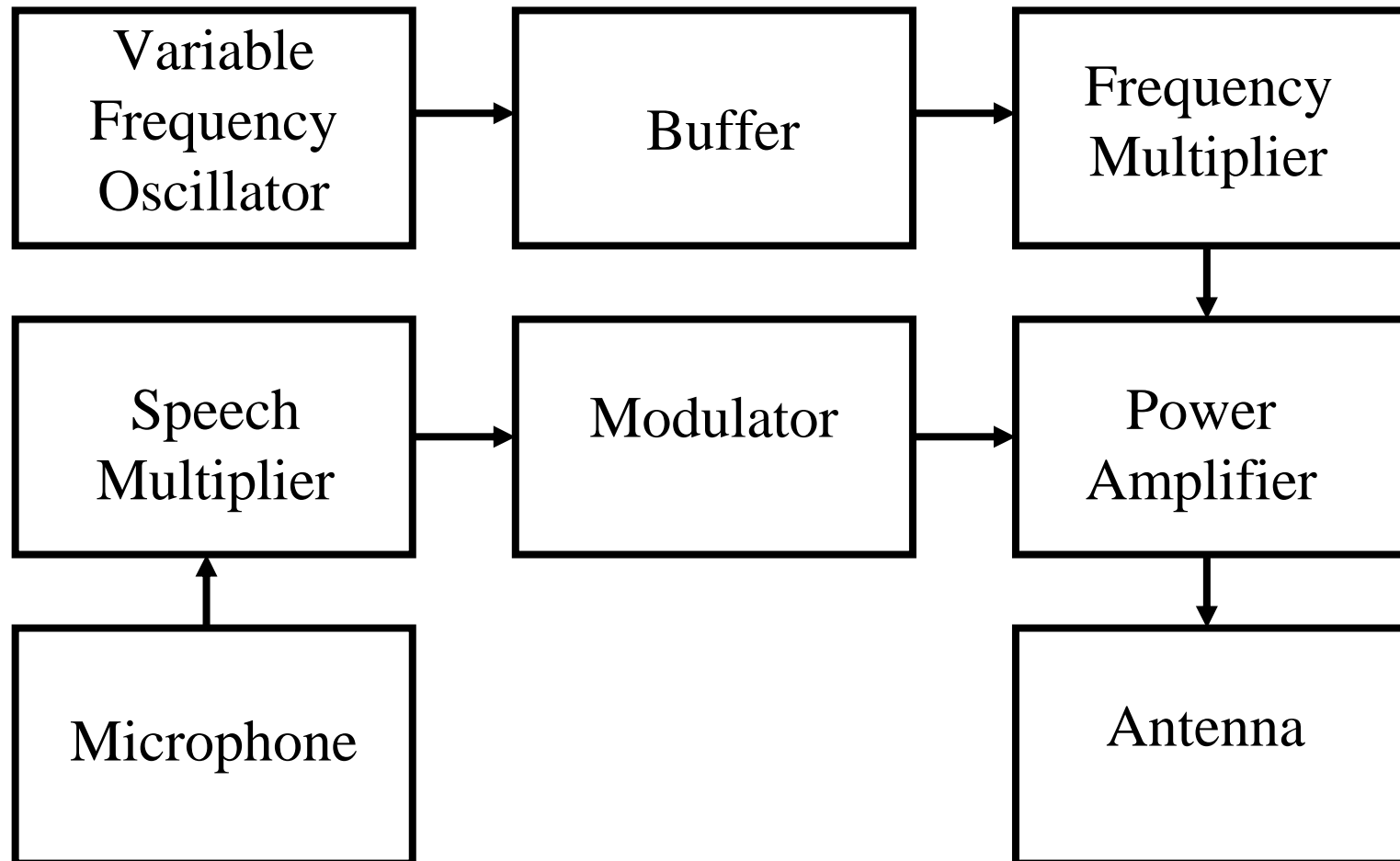

AM Transmitter

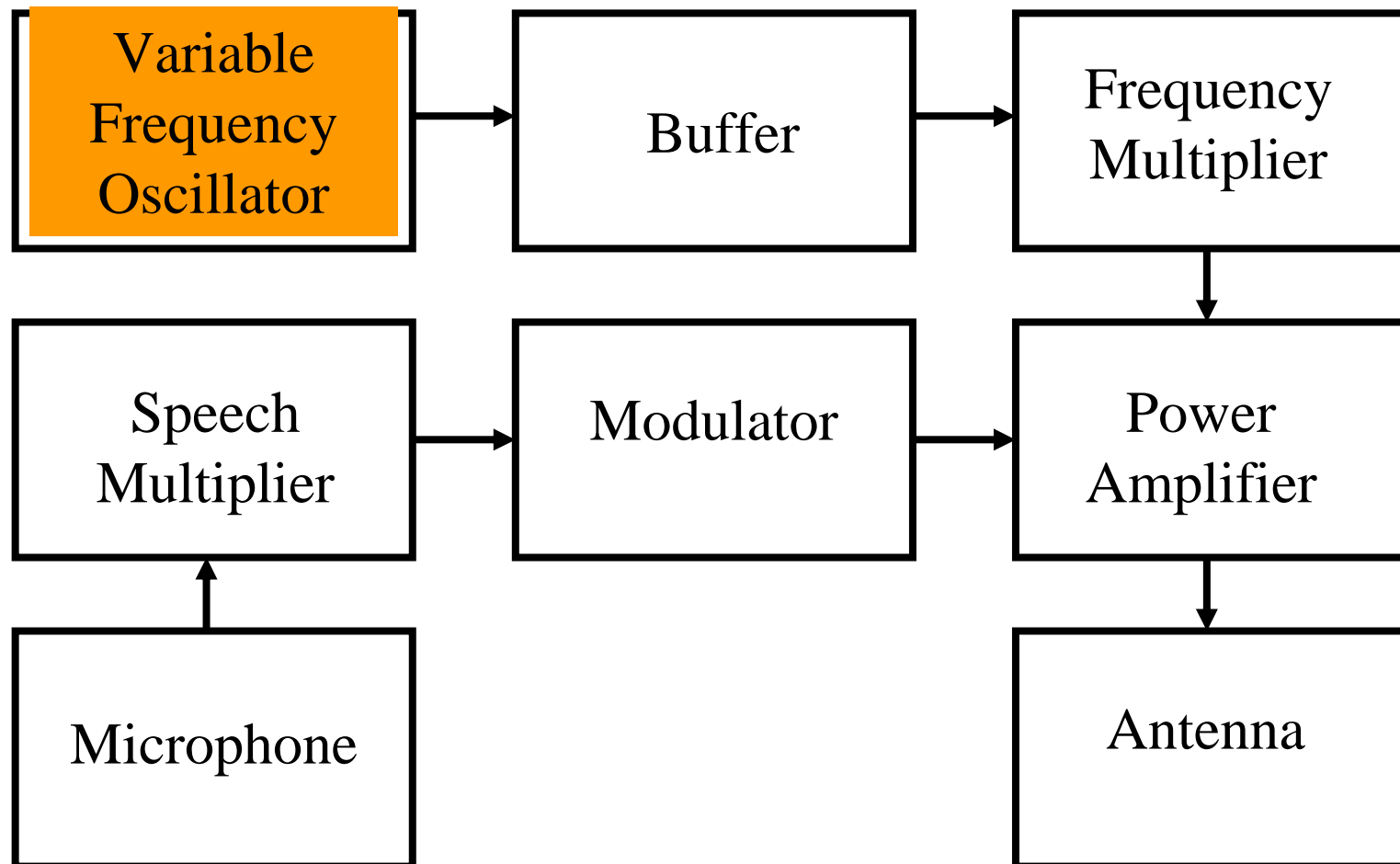

Variable Frequency Oscillator

- The **VFO** has replaced the Master Oscillator in the CW transmitter. It could have been used in the CW transmitter, or any of the transmitters described here.
- Instead of a fixed frequency, it can **vary over a range of frequencies.**
- The **Buffer isolates the VFO** from the **Frequency Multiplier stage.**

AM Transmitter

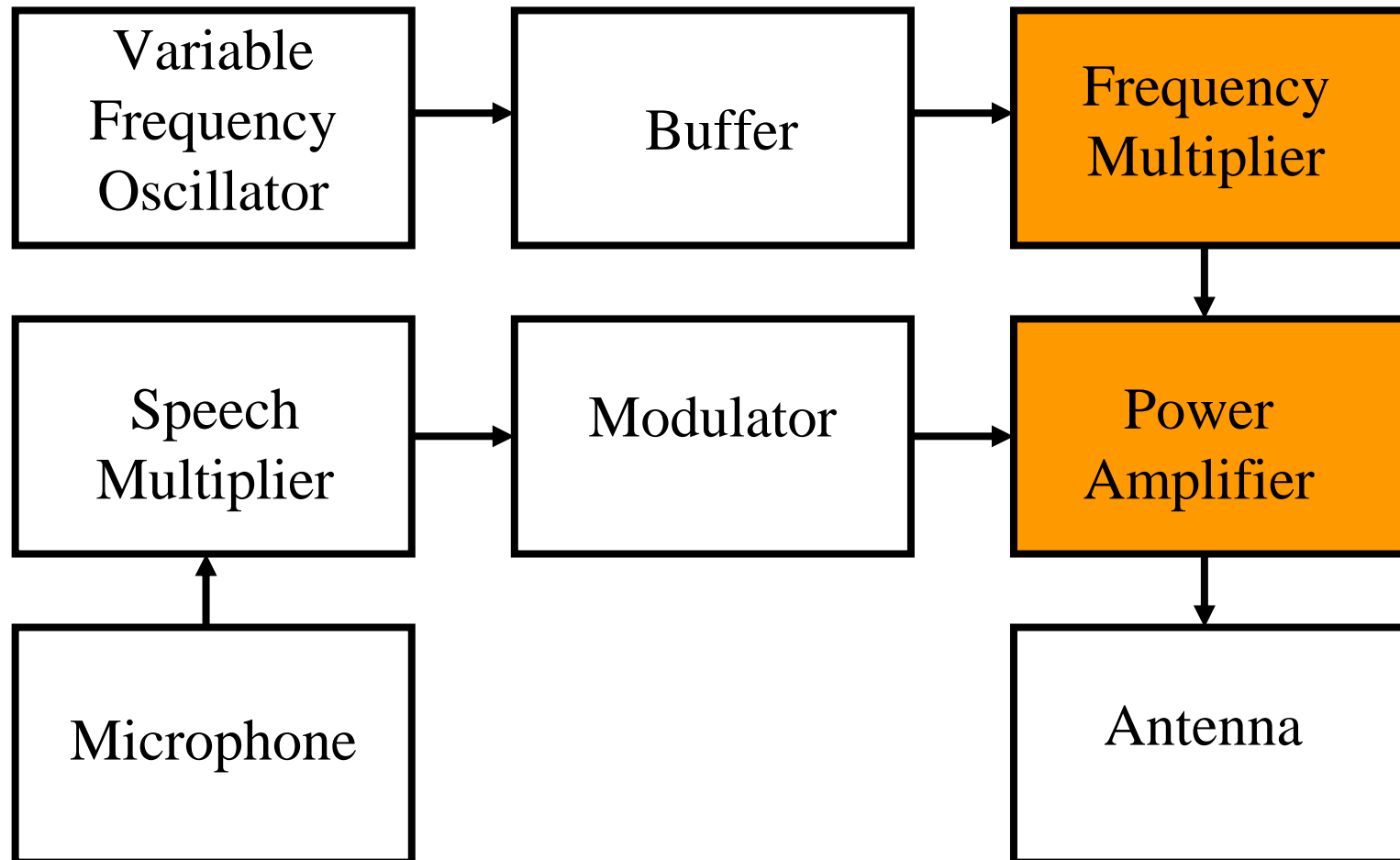

Frequency Multiplier and PA

- The **Frequency Multiplier** multiplies the frequency generated by the VFO to bring it to the desired frequency.
- The **PA amplifies** the RF signal delivered by the Frequency Multiplier, but has other duties as well in an AM transmitter.

AM Transmitter

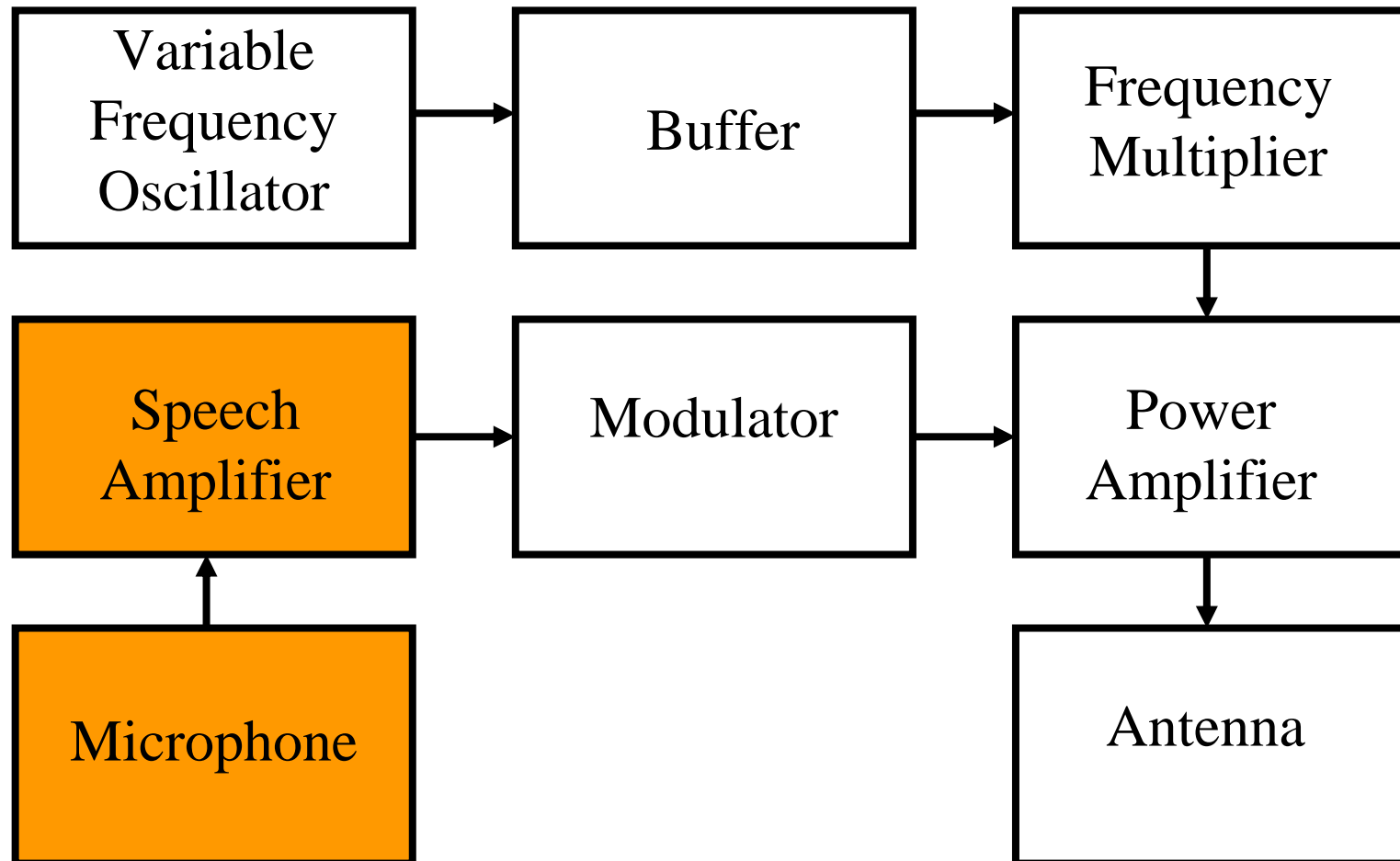

Microphone and Speech Amplifier

- The **Microphone** produces a **low output voltage**, generally in the range of a **few tens of millivolts**.
- It is **amplified** by the **Speech Amplifier** to the level **required by the modulator**.
- In general, the audio for all Amateur AM, SSB and FM transmitters is processed so that the modulated power is contained in the most useful region, typically **300 to 3000 Hz**. *(Note that there is a typo in your book.)*

AM Transmitter

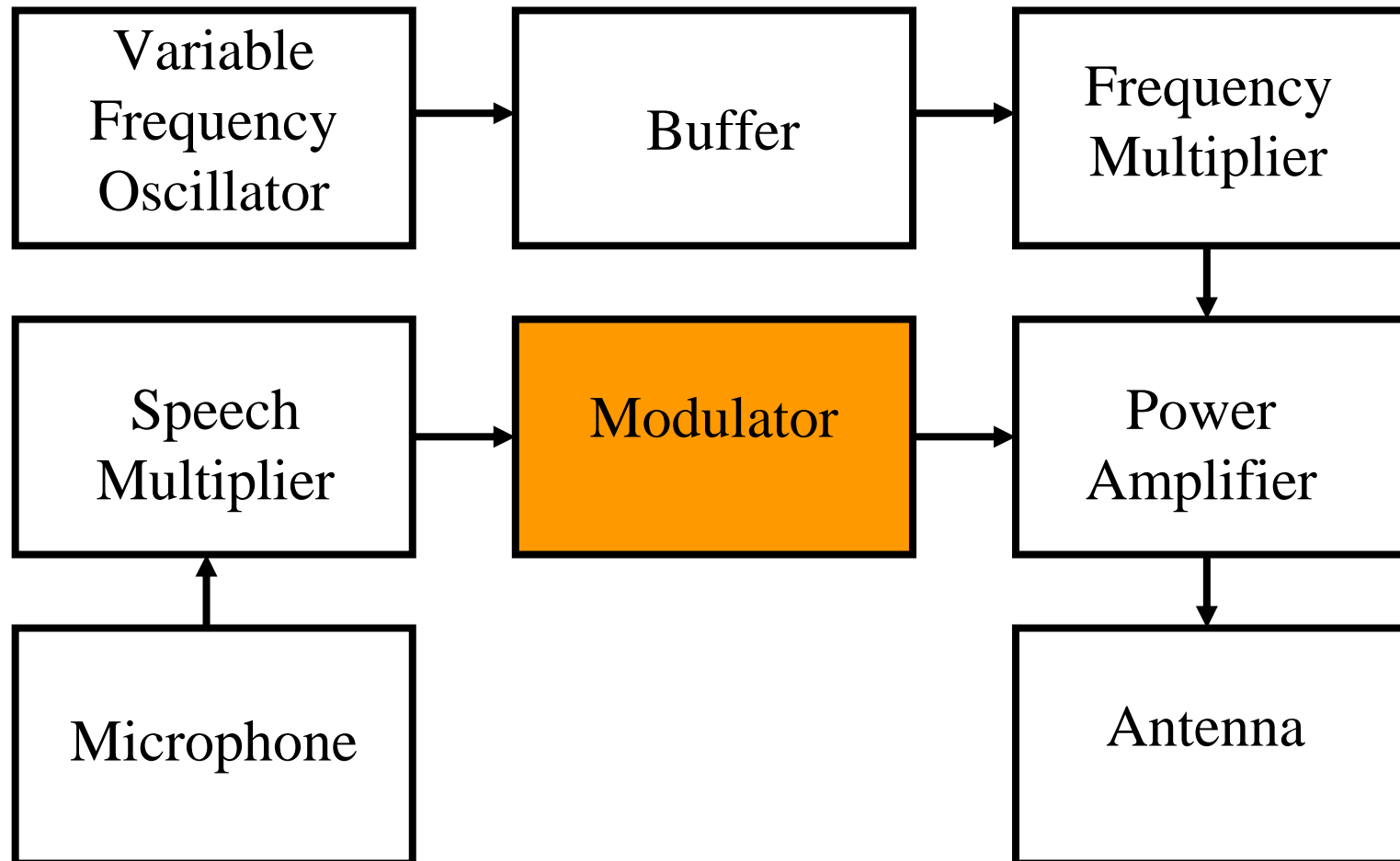

Modulator

- The **Modulator** changes the **amplitude of the RF signal** to vary in accordance with the **speech characteristics**.
- The output of the **Frequency Multiplier** stage and the **Modulator** are **combined in the PA** to create the **final signal**, which is delivered to the **antenna and radiated**.

FM Transmitter

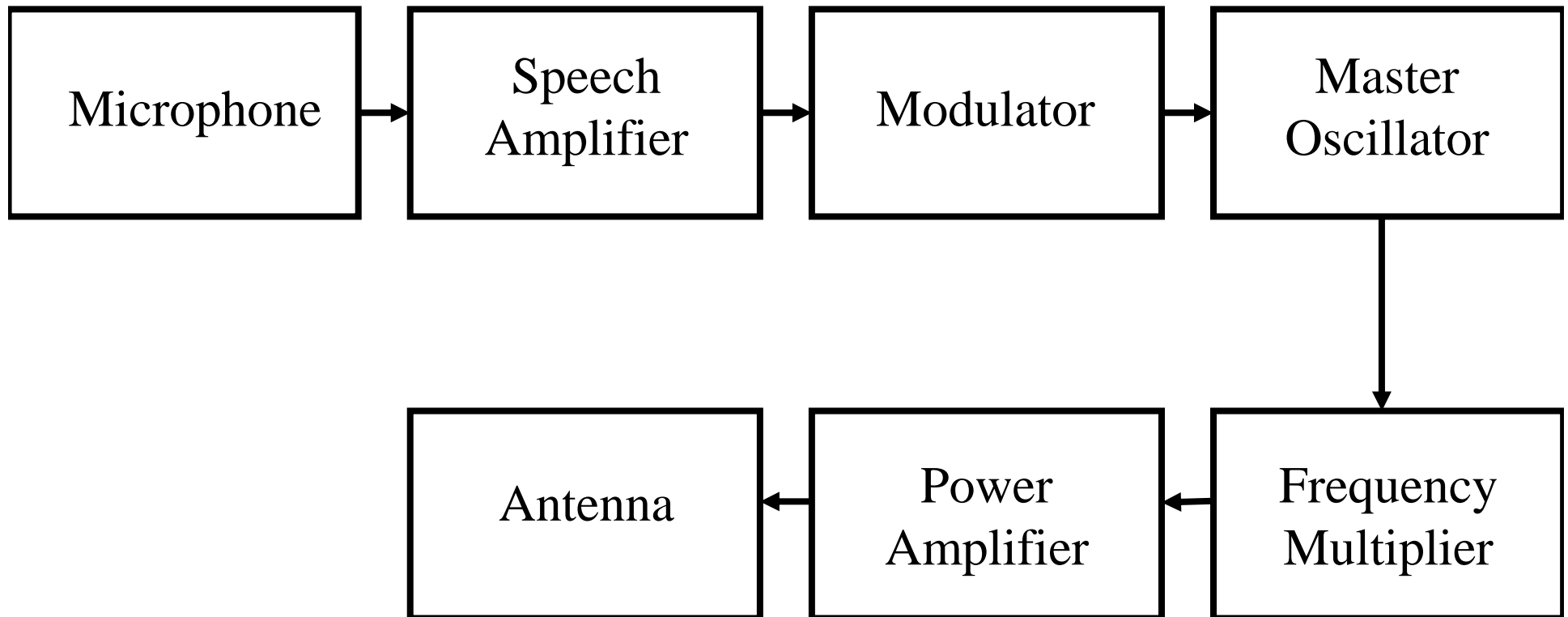

FM Transmitter

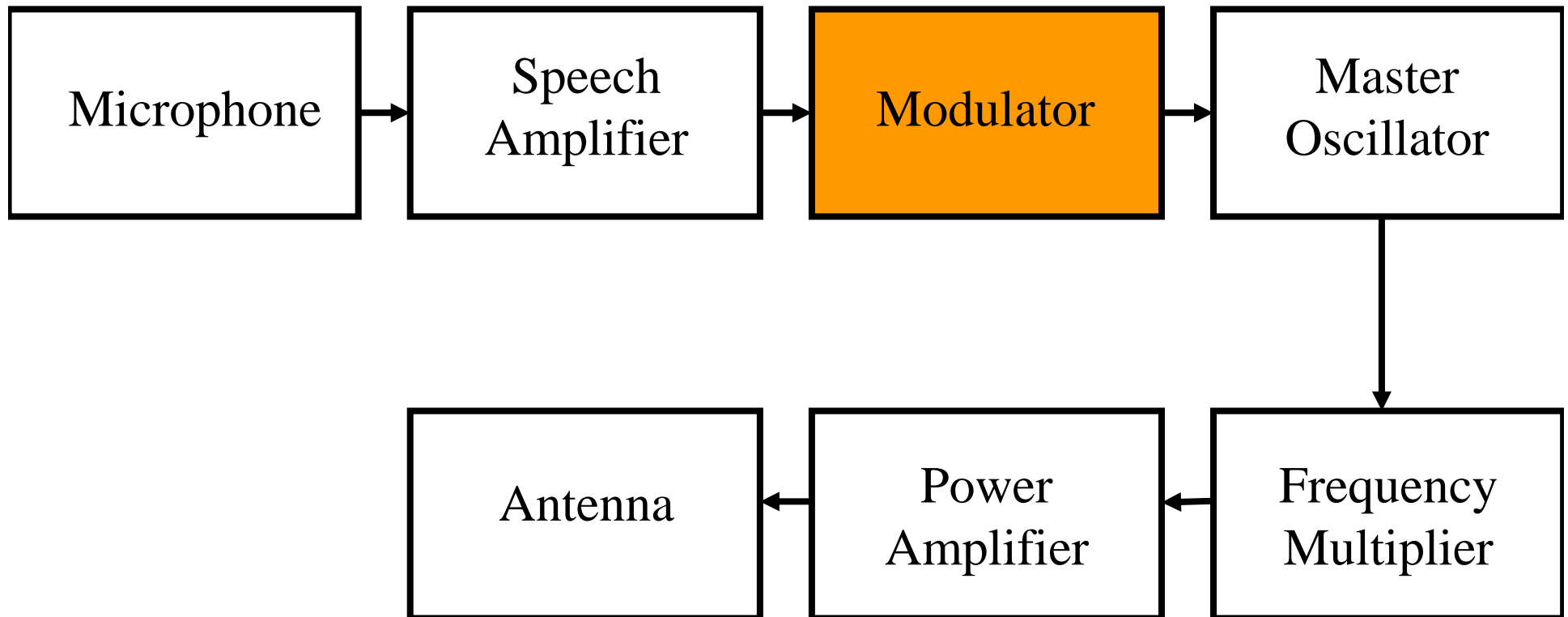

FM Modulator

- Sometimes called a **Reactance Modulator**, the **output from the Modulator** is applied to the **input of the Master Oscillator** to **vary its frequency**.
- The **amount of frequency variation** is generally **small**, so the Master Oscillator is generally operated at a fraction (say $1/8^{\text{th}}$) of the desired frequency.

FM Transmitter

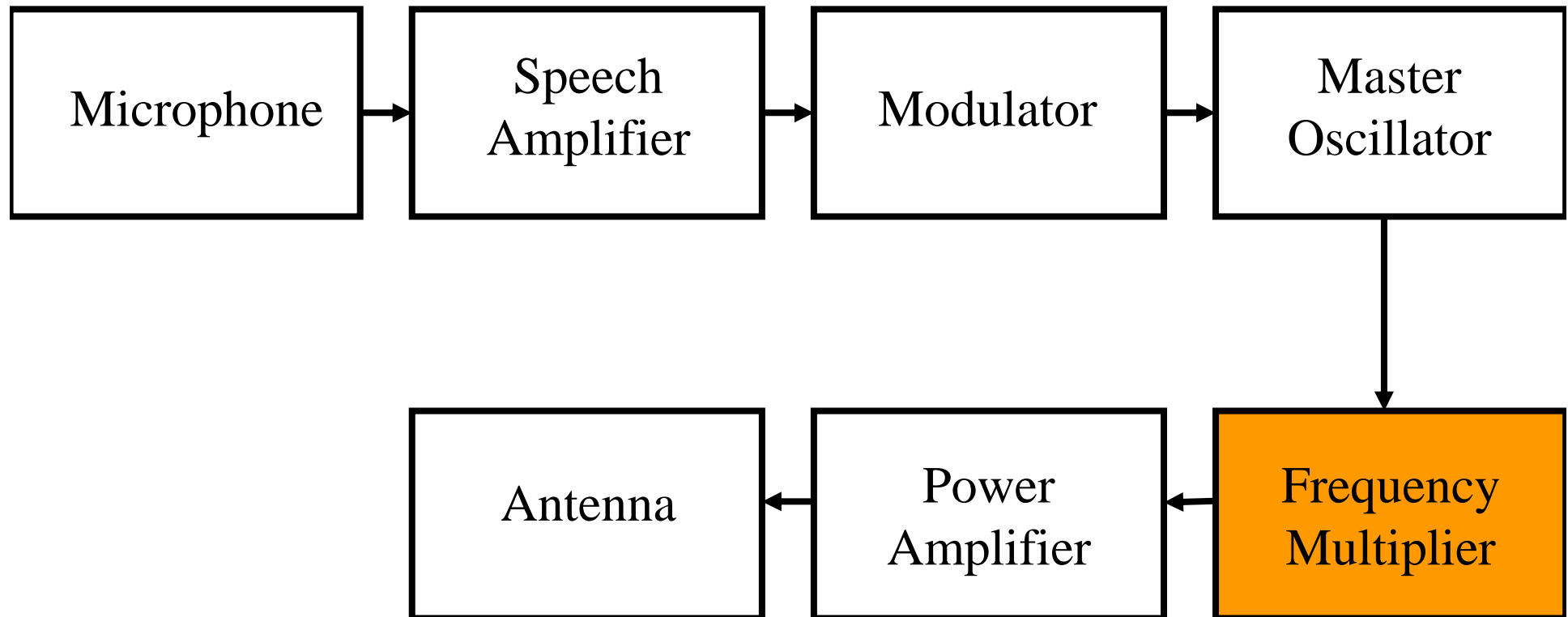

Frequency Multiplier

- The **output** from the **Master Oscillator** is **doubled and tripled** as required to **produce RF** in the **desired range**.
- This stage also acts as a **buffer** for the **Master Oscillator**.

SSB Transmitter

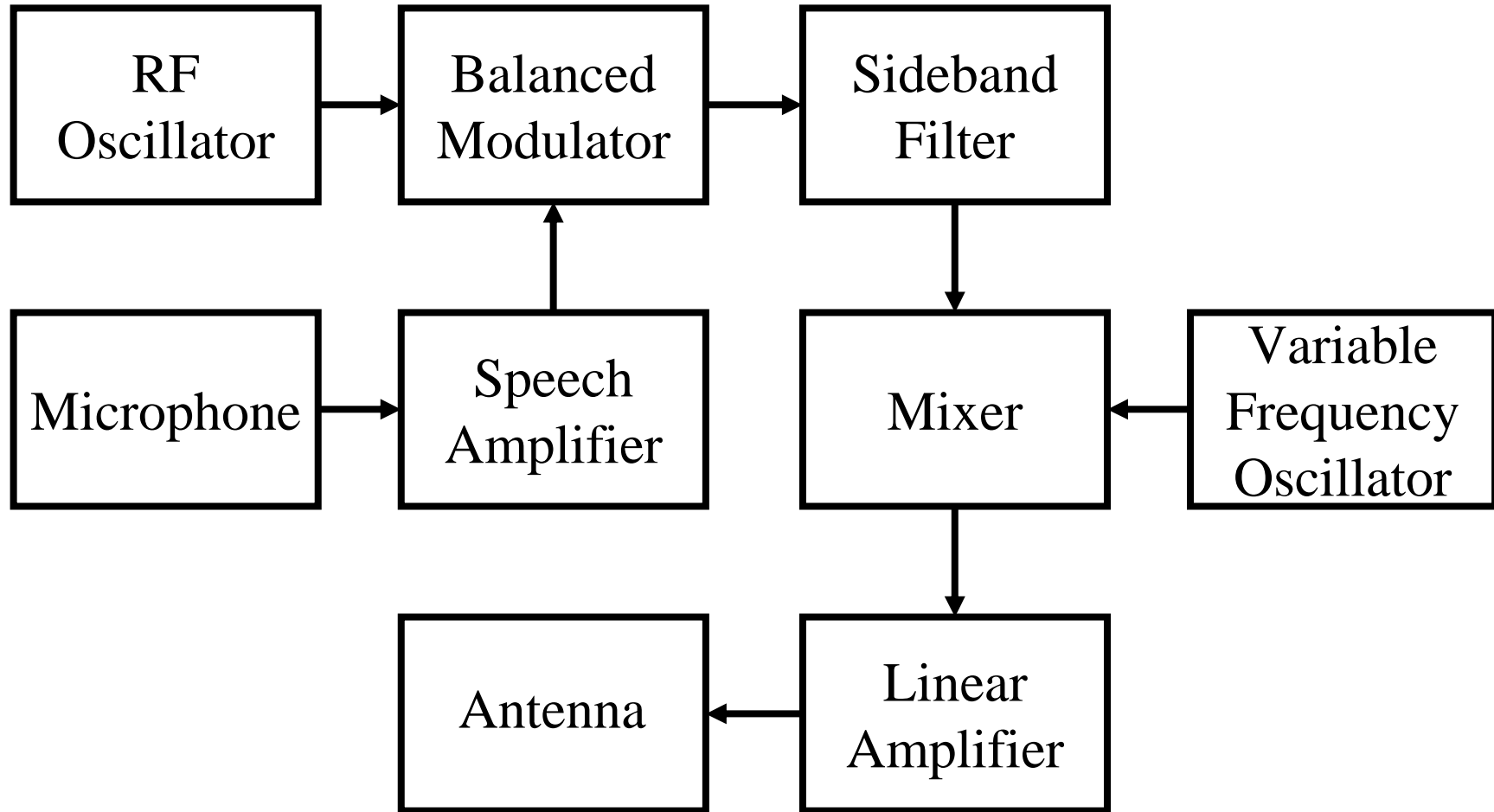

SSB Transmitter

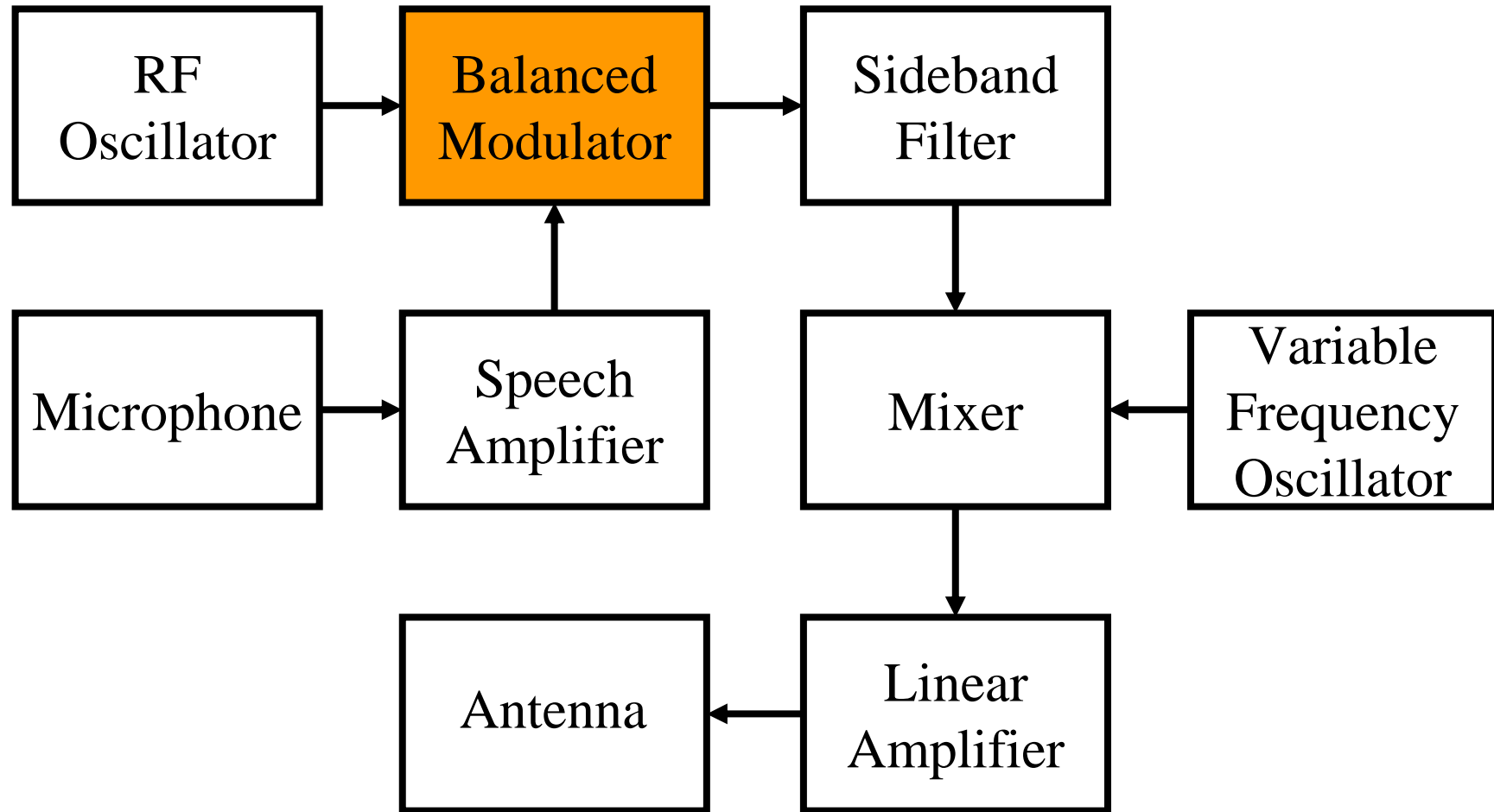

Balanced Modulator

- A **Balanced Modulator** is fed with an **RF carrier** and an **audio frequency**, but passes only the **two AM sidebands** while **suppressing the original RF carrier**.
- For example, if the **RF carrier is 500 KHz**, and it is mixed with an audio signal at **2 KHz**, the output is **498 KHz** in the lower sideband, and **502 KHz** in the upper sideband.

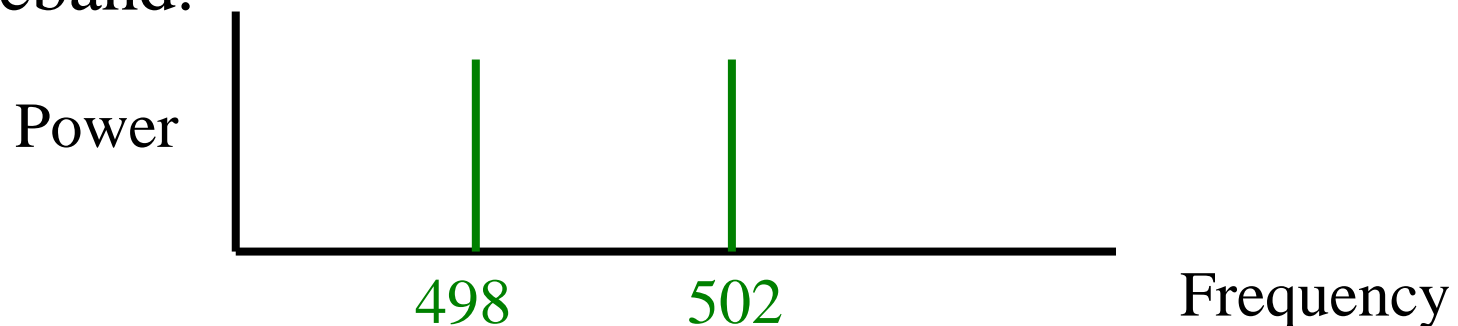

SSB Transmitter

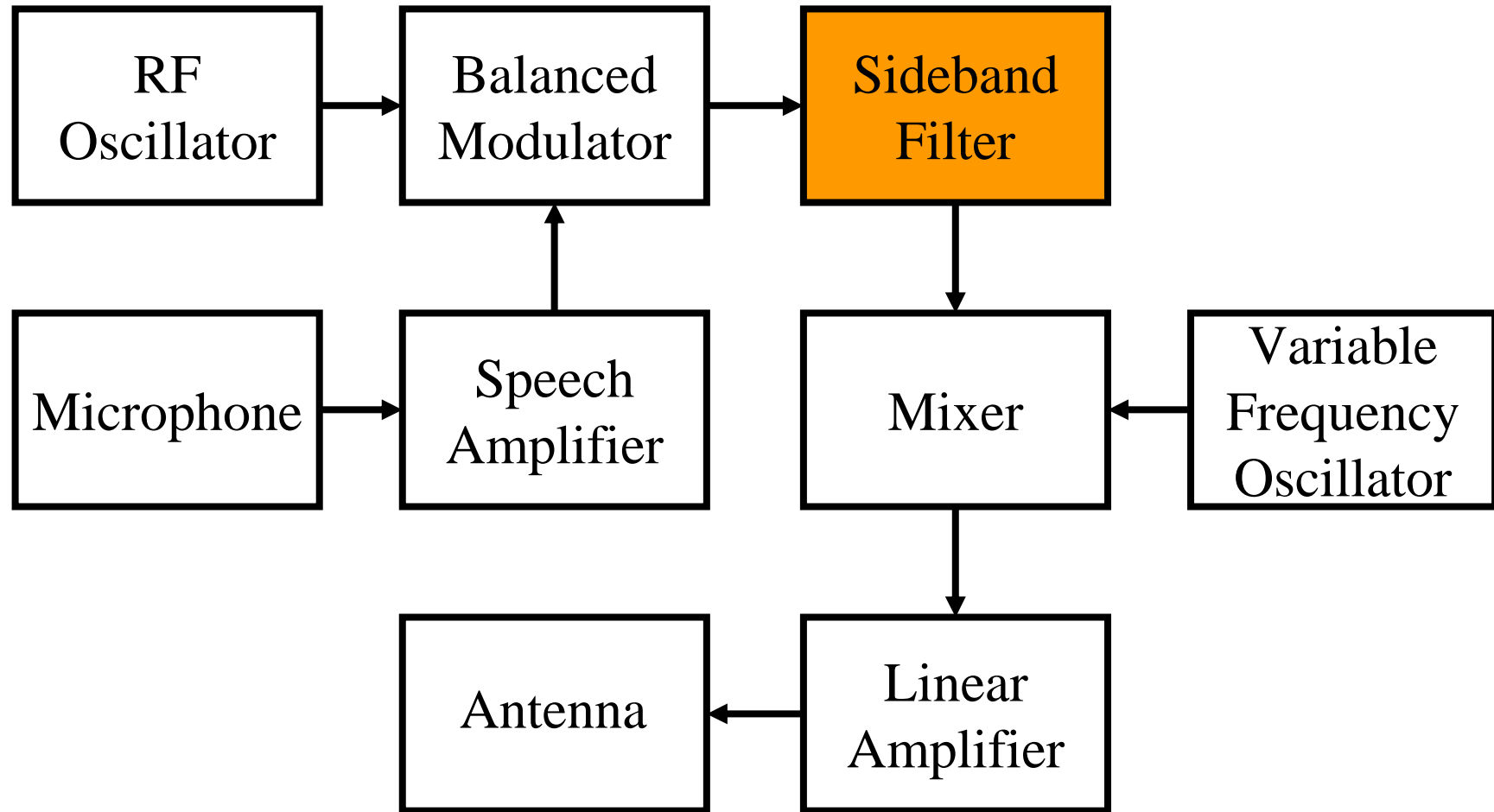

Sideband Filter

- The **Sideband Filter** selects the **desired sideband**.
- In the previous example it would **pass the frequency band from 500.3 to 503 for USB, and 497 to 499.7 for LSB**.
- The **output** from the filter is a **Single Sideband Suppressed Carrier** signal.

SSB Transmitter

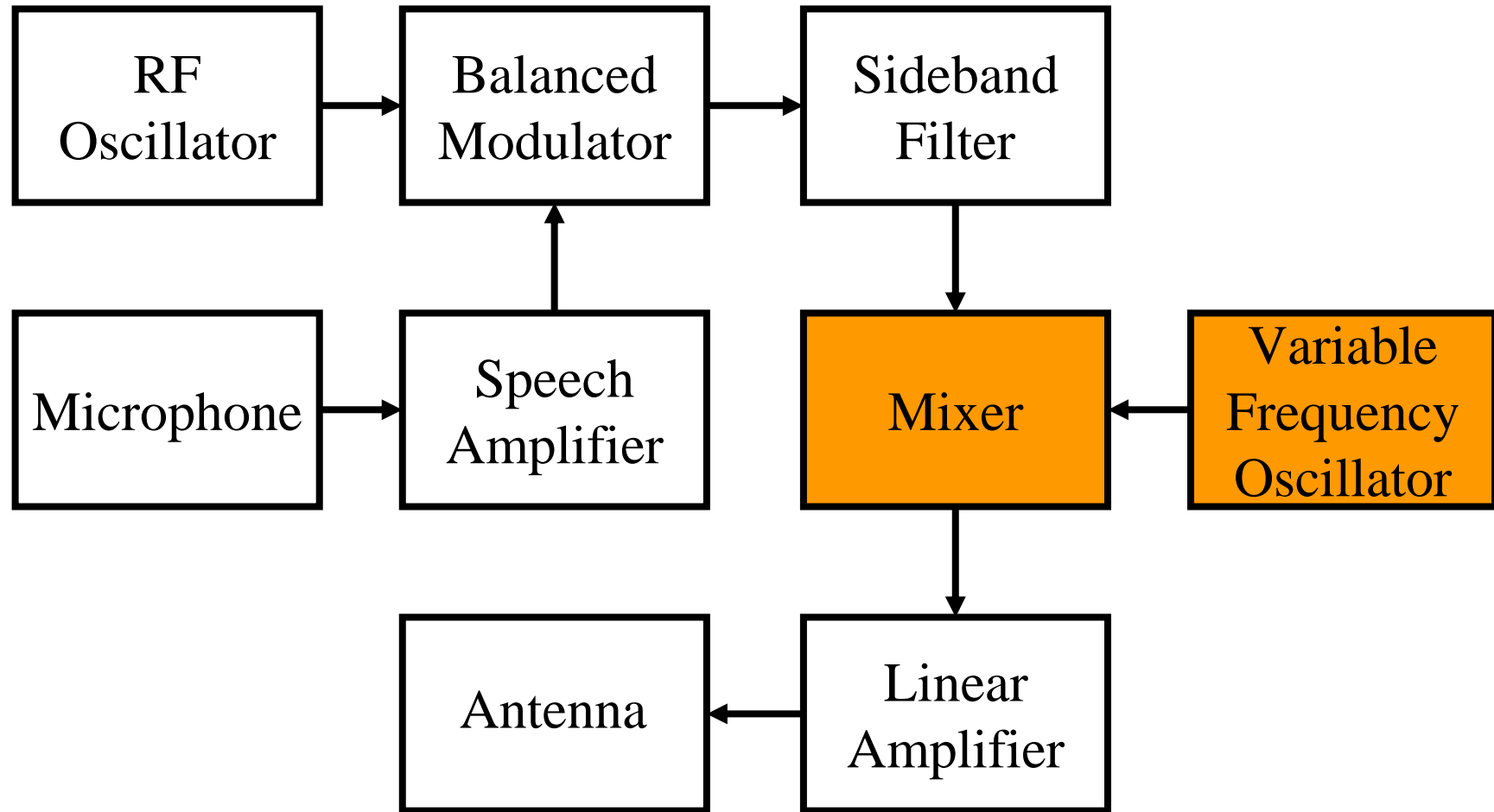

VFO and Mixer

- The **Mixer** will **mix the inputs** from the **Sideband Filter** and the **VFO** to generate the **desired transmit frequency**.
- The **Mixer** will **generate the sum and difference** of the two frequencies, and the **desired signal is selected** while the other is filtered out.

Mixing to Generate Transmit Signal

- If the **output** of the Sideband Filter stage is centered on **500 KHz (0.5 MHz)**, and we wish to operate in the 40M band (7.0 to 7.3 MHz), then we will need a **VFO** operating over the range of **6.5 to 6.8 MHz**.

$$6.5 \text{ MHz} + 0.5 \text{ MHz} = 7.0 \text{ MHz}$$

$$6.8 \text{ MHz} + 0.5 \text{ MHz} = 7.3 \text{ MHz}$$

- Note that **frequency multiplication cannot** be used to generate the desired transmit frequency as **passing an SSB signal** through a **frequency multiplier** would cause **severe distortion**.

SSB Transmitter

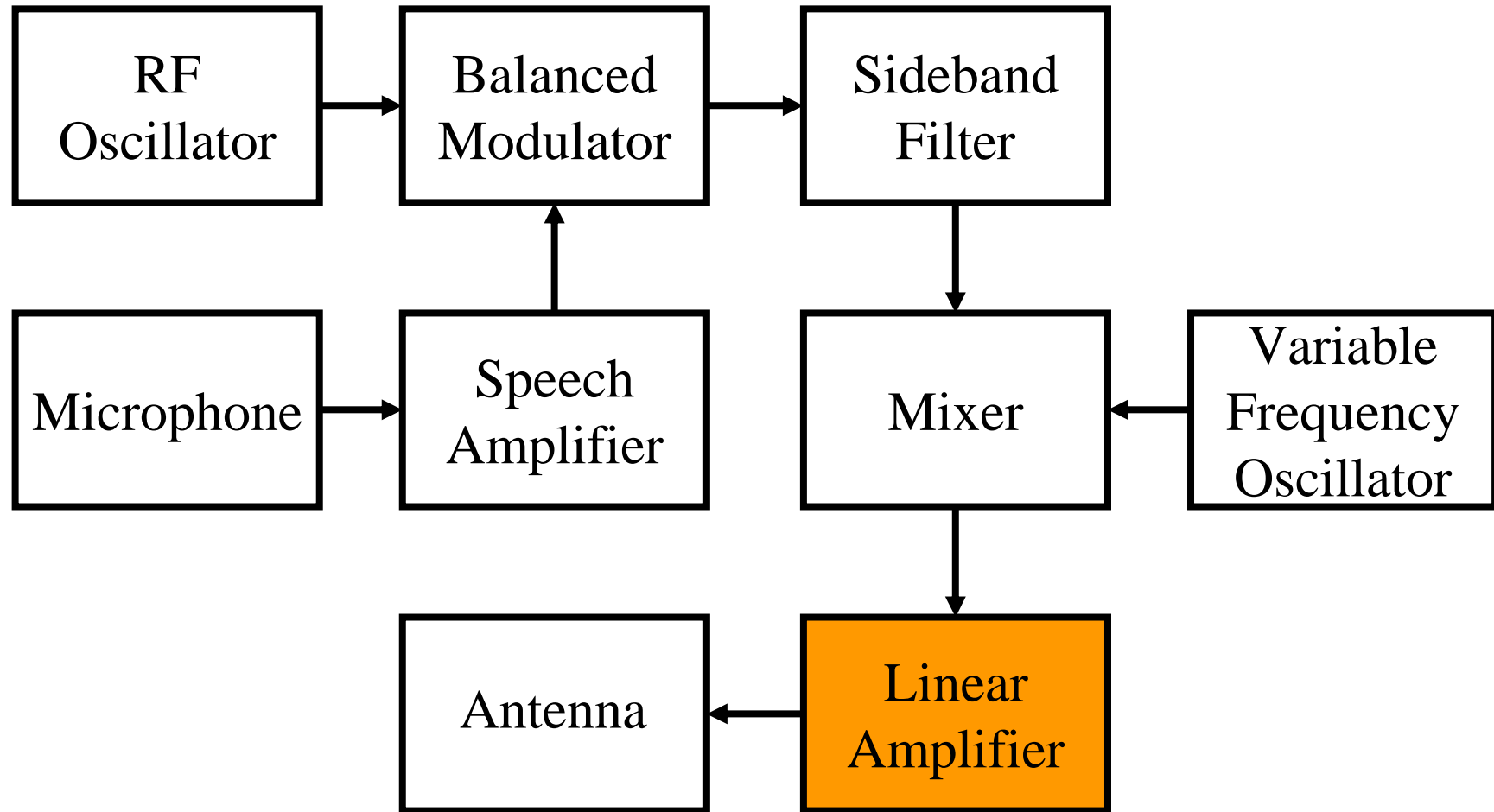

Linear Amplifier

- The **PA** of an **SSB transmitter must be linear** to avoid causing **distortion and splatter**.
- A **linear amplifier** will increase the power of an amplitude modulated signal without causing such distortion.
- If the **speech amplifier, mixer or linear amplifier** are overdriven, “**flat-topping**” may occur. This can lead to **interference with adjacent stations** and even your **neighbour’s TV**.
- The **Microphone gain MUST be correctly set** – increasing mic gain does not increase the output power.

Transmit / Receive Switch

- The **antenna** is usually **common** to both the **transmitter and receiver**, so we need a method to keep the **high power** from the **transmitter** out of the sensitive input of the **receiver**.
- **T/R Switch** can be either **mechanical (relay)** or **electronic (switching diodes)**.
- It **switches the antenna** between the TXmtr and RXer, and may also **ground the RX** input on transmitting, or **turn the TXmtr** off when receiving.
- Usually built-into modern transceivers.

T-R SWITCH

CATALOG NO. 250-39



FULL AUTOMATIC MECHANICAL
ANTENNA TRANSFER SWITCH
FREQUENCY RANGE 1.5-15 MC
POWER 4000 WATTS PEP

E. P. JOHNSON CO.
WASHTON, WISCONSIN U.S.A.

ANTENNA



PHONE



TRANSMITTER



RECEIVER



Questions

